

Operating and Assembly Instructions

Universal Encoder System U-ONE®

Basic units

UOM 4L-1212

UOMH 4L-1212

Electronic function modules

UO EM-D2

UO EM-FG4

UO EM-EGS®4

UO EM-AMC

UO EM-AMP

UO EM-AMS

UO EM-AME/M

UO EM-ERC

Read the Operating and Assembly Instructions prior to assembly, starting installation and handling!

Keep for future using!

Translation of the original Operating and Assembly Instructions

U-ONE_MANUAL-en_R0(2011-02-11)



Trademark

U-ONE® is a registered trademark of Johannes Hübner - Fabrik elektrischer Maschinen GmbH, Giessen.

Windows is a registered trademark of Microsoft Corporation in the United States and other countries. All other brand names and product names are trademarks or registered trademarks of their respective owner.

Protected trademarks bearing a ™ or ® symbol are not always depicted as such in the manual. However, the statutory rights of the respective owners remain unaffected.

Manufacturer / publisher

Johannes Hübner
Fabrik elektrischer Maschinen GmbH, Giessen
Siemensstraße 7
35394 Giessen

Germany

Phone: +49 (0) 641 / 7969-0
Fax: +49 (0) 641 / 73645
E-Mail: info@huebner-giessen.com
www.huebner-giessen.com

Headquarters: Giessen
Court of registration: Giessen
Commercial register number: HRB 126
Joint Managing Directors: Dieter Wulkow
Oliver Rüspler

This manual has been drawn up with the utmost care and attention. Nevertheless, we cannot exclude the possibility of errors in form and content. It is strictly forbidden to reproduce this publication or parts of this publication in any form or by any means without the prior written permission of Johannes Hübner Fabrik elektrischer Maschinen GmbH, Giessen. Subject to errors and changes due to technical improvements.

Published February 2011

Copyright © Johannes Hübner – Fabrik elektrischer Maschinen GmbH, Giessen.

All rights reserved.

Directory

1	General	5
1.1	Information about the Operating and Assembly Instructions	5
1.2	Scope of delivery	5
1.3	Explanation of symbols	5
1.4	Disclaimer	6
1.5	Manufacturer's Declaration	6
1.6	Copyright.....	6
1.7	Guarantee terms.....	6
1.8	Customer service.....	6
2	Safety.....	6
2.1	Responsibility of the owner.....	6
2.2	Intended use	6
2.3	Non intended use.....	7
2.4	Personal protective equipment	7
2.4.1	Special dangers.....	8
2.4.2	Electrical current.....	8
2.4.3	Rotating shafts	8
2.4.4	Safeguarding against restart.....	8
3	Technical data.....	9
3.1	Type plate	9
3.2	Electrical and mechanical data	9
3.2.1	Basic Unit UOM 4L-1212.....	9
3.2.2	Fiber optic decoder UO-EM-D2 / for decoding the optical (fibre optic) signals of the basic unit and supply of electronic function modules	12
3.2.3	Electronic Module Incremental Encoder UO-EM-FG 4.....	13
3.2.4	Electronic Module Electronic Overspeed Switch UO-EM-EGS 4.....	14
3.2.5	Electronic Module Absolute Encoder CAN-Bus interface UO-EM-AMC	15
3.2.6	Electronic Module Absolute Encoder PROFI-Bus interface UO-EM-AMP	16
3.2.7	Electronic Module Absolute Encoder Multiturn with SSI-interface UO-EM-AMS ...	17
3.2.8	Electronic Module Absolute Encoder Multiturn, with Ethernet-interface UO-EM-AME/M	18
3.2.9	Electronic Module Position Switch UO-EM-ERC.....	19
4	Transport, packaging, and storage	20
4.1	Instructions for transport.....	20
4.2	Incoming goods inspection	20
4.3	Symbols on the packaging.....	20
4.4	Transport inspection	20
4.5	Packaging	20
5	Installation and commissioning.....	21
5.1	Safety instructions	21
5.2	Mounting of the basic unit (mechanically)	21

5.3	Mounting of the basic unit / Modules	22
5.3.1	Mounting of the Basic unit	22
5.3.2	Mounting the modules	22
6	Disassembly.....	23
6.1	Safety tips	23
6.2	Disassembly.....	23
7	Troubles	23
8	Maintenance.....	25
8.1	Safety tips	25
8.2	Maintenance	25
8.3	Inspection Plan	25
9	Disposal.....	25
9.1	Disposal drain	25
10	Declaration of Conformity	26
11	Intallation instructions for couplings	27
12	Index	28

1 General

1.1 Information about the Operating and Assembly Instructions

This Operating and Assembly Instructions provides important instructions for working with the device. It must be carefully read prior to starting all tasks, and the instructions contained herein must be followed.

In addition, applicable local regulations for the prevention of industrial accidents and general safety regulations must be complied with.

1.2 Scope of delivery

Scope of delivery includes the Universal Encoder System U-ONE® and the Operating and Assembly Instructions.

1.3 Explanation of symbols

Warnings are indicated by symbols in this operating manual. The warnings are introduced by signal words that express the scope of the hazard.

The warnings must be strictly heeded; you must act prudently to prevent accidents, personal injury, and property damage.



WARNING!

Indicates a possibly dangerous situation that can result in death or serious injury if it is not avoided.



CAUTION!

Indicates a possibly dangerous situation that can result in minor injury if it is not avoided.



CAUTION!

Indicates a possibly dangerous situation that can result in material damage if it is not avoided.



NOTES!

Indicates useful tips and recommendations as well as information for efficient and trouble-free operation.



NOTES!

Mounting and disassembly by means of a hammer or similar tools is not permitted (warranty void).



DANGER!

Life-threatening danger due to electric shock!

Indicates a life-threatening situation due to electric shock. If the safety instructions are not complied with there is danger of serious injury or death. The work that must be executed should only be performed by a qualified electrician.

1.4 Disclaimer

All information and instructions in this Operating and Assembly Instructions have been provided under due consideration of applicable guidelines, as well as our many years of experience.

The manufacturer assumes no liability for damages due to:

- Failure to follow the instructions in the manual
- Non-intended use
- Deployment of untrained personnel
- Opening of the device or conversions of the device

In all other aspects the obligations agreed in the delivery contract as well as the delivery conditions of the manufacturer apply.

1.5 Manufacturer's Declaration

The device is tested in accordance with EC Directive 2006/42/EG.

1.6 Copyright



NOTE!

Content information, text, drawings, graphics, and other representations are protected by copyright and are subject to commercial property rights.

1.7 Guarantee terms

The guarantee terms are provided in the manufacturer's terms and conditions.

1.8 Customer service

For technical information personnel are available that can be reached per telephone, fax or email, see manufacturer's address on page 2.

2 Safety



This section provides an overview of all the important safety aspects that ensure protection of personnel, as well as safe and trouble-free device operation. If these safety instructions are not complied with significant hazard can occur.

2.1 Responsibility of the owner

The device is used in commercial applications. Consequently the owner of the device is subject to the legal occupational safety obligations, and subject to the safety, accident prevention, and environmental protection regulations that are applicable for the device's area of implementation.

2.2 Intended use

The device has been designed and constructed exclusively for the intended use described here.

Universal Encoder Systems U-ONE and the electronic function modules are used for speed measuring overspeed and position.

Claims of any type due to damage arising from non-intended use are excluded; the owner bears sole responsibility for non-intended use.

2.3 Non intended use

- Do not use the device in potentially explosive areas.
- The device must not be subjected to mechanical loads in addition to its own weight and unavoidable vibration and shock loads that arise during normal operations.

Examples for non-permitted mechanical loads (incomplete list):

- Fastening transport or lifting tackle to the device, for example a crane hook to lift a motor.
 - Fastening packaging components to the device, for example ratchet straps, tarpaulins etc.
 - Using the device as a step, for example by people to climb onto a motor.
- It is not permitted to use the device in locations higher than 3000 m above sea level.

2.4 Personal protective equipment

For tasks such as assembly, disassembly or commissioning the use of personal protective equipment such as safety footwear and protective work clothing is required.

The regulations specified by the owner and that are locally specified apply.

2.4.1 Special dangers

Residual risks that have been determined based on a risk analysis are cited below.

2.4.2 Electrical current



DANGER!

Life-threatening danger due to electrical shock!

There is an imminent life-threatening hazard if live parts are touched. Damage to insulation or to specific components can pose a life-threatening hazard.

Therefore:

Immediately cut off the device and have it repaired if there is damage to the insulation of the power supply.

De-energize the electrical equipment and ensure that all components are connected for all tasks on the electrical equipment.

Keep moisture away from live parts. Moisture can cause short circuits.

2.4.3 Rotating shafts



WARNING!

Danger of injury due to rotating shafts!

Touching rotating shafts can cause serious injuries.

Therefore:

Do not reach into moving parts/shafts or handle moving parts/shafts during operation.

Do not open covers during operation. Prior to opening the covers ensure that all parts have come to a standstill.

2.4.4 Safeguarding against restart



DANGER!

Life-threatening danger if restarted without authorization!

When correcting faults there is danger of the power supply being switched on without authorization.

This poses a life-threatening hazard for persons in the danger zone.

Therefore:

Prior to starting work, cut off the system and safeguard it from being switched on again.

3 Technical data

3.1 Type plate



The type plate is located on the outside of the housing and contains the following information:

- Manufacturer, Address
- Type
- CE-marking
- Serial number (S/N)
- Year of construction (Y)
- Power supply

3.2 Electrical and mechanical data

3.2.1 Basic Unit UOM 4L-1212

Basic unit UOM 4L-1212 One or two free shaft extensions:	Electrical Data	Unit
	Supply voltage	12 – 30 V DC
	Power consumption	Max. 2 W
	Incremental	1024 symmetrical square wave pulses
	Absolute singleturn	12 Bit (4096 steps/rev.)
	Absolute multiturn	12 Bit (4096 rev.)
	Signal transmission	Optical for fibre optic cable
	Connection scheme	EL 667
	Temperature range electronics	-25 up to +85°C

Basic unit UOM 4L-1212:	Mechanical Data	Unit
	Shaft types	11j6x30 mm
	Protection types	IP 55 or IP 66 acc. to EN 60529
	Max. perm. speed	3000 rpm 2000 rpm (hollow shaft design)
	Connection	Terminal box COMBICON terminal strip (supply voltage) 2 x ST-plug connections for fibre optic cable 50/125µm or 62,5/125µm

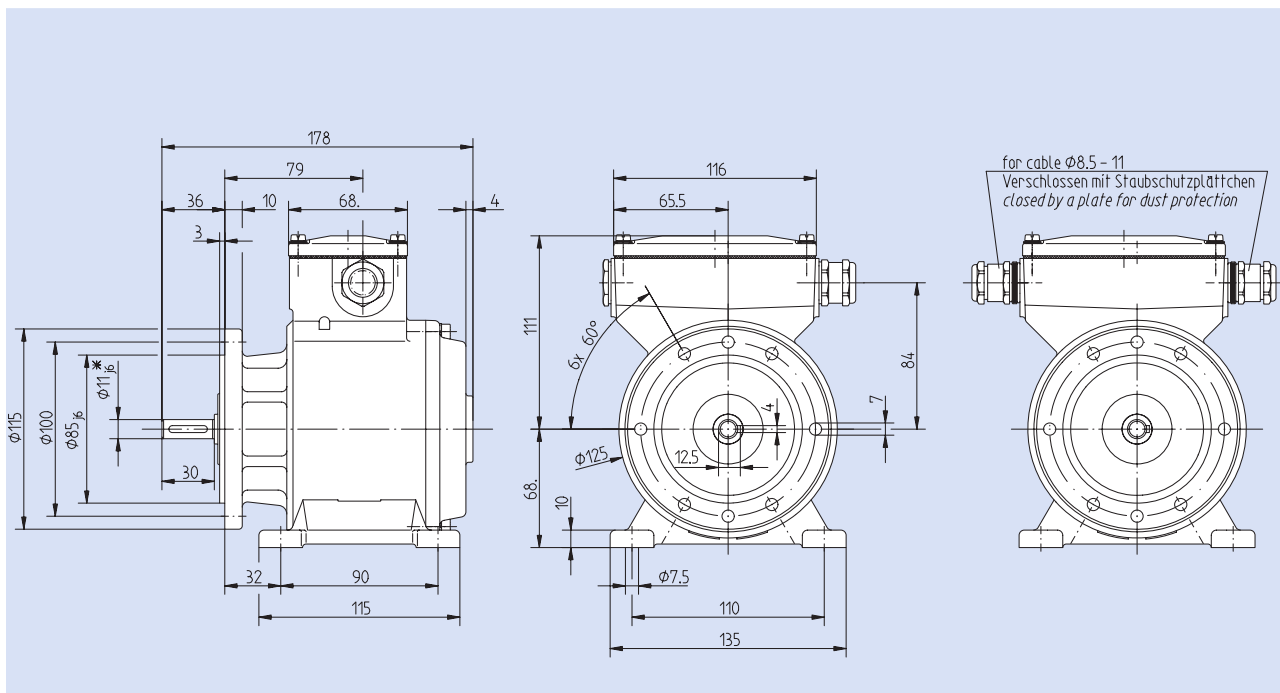

U-ONE

Construction type B35

HM 01 M 55389

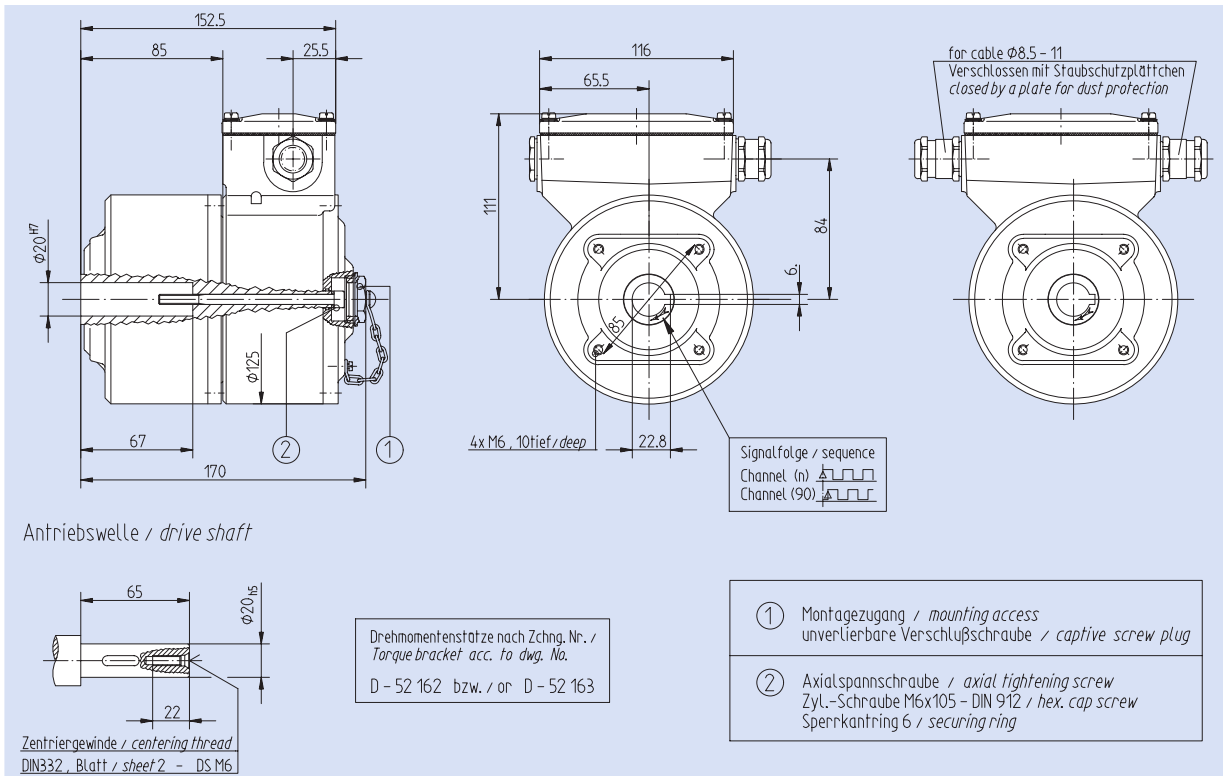

U-ONE **Hollow shaft** **HM 05 M 56 345**

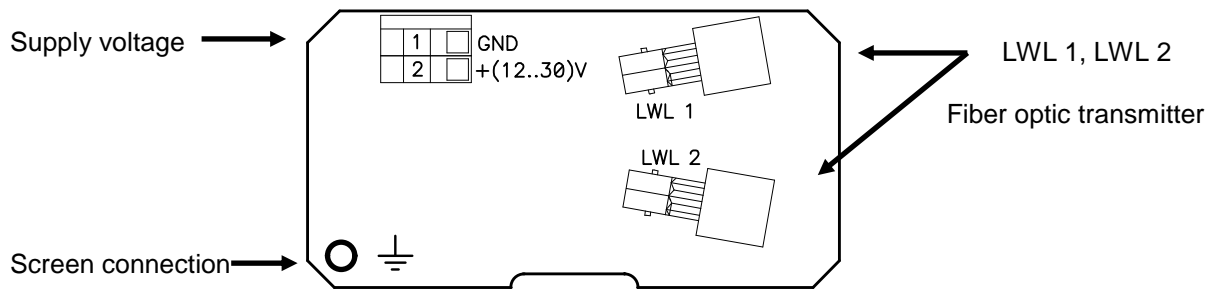

3.2.2 Fiber optic decoder UO-EM-D2 / for decoding the optical (fibre optic) signals of the basic unit and supply of electronic function modules

Supply voltage	12 up to 30 V DC
power consumption	max. 1 W plus power consumption of next modules
connections	ST-plug connection for fiber optic COMBICON-terminal strip for supply voltage
Output	Internal bus connection to next modules incl. power supply
Programming Interface	RS 232
Connection diagram	EL 668a
Temperature range	-25 up to + 70 °C

Dimension drawing

A = 114,50 mm B = 22,50 mm

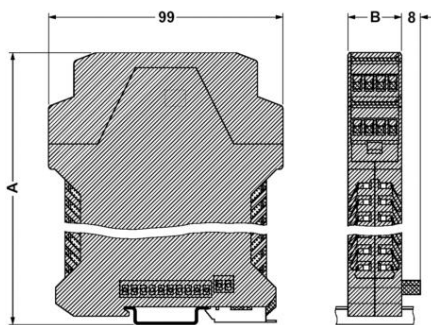

connection diagram

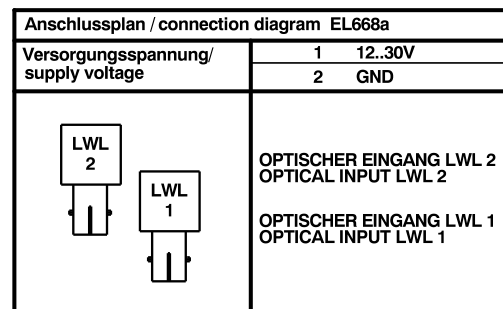
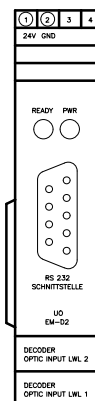

3.2.3 Electronic Module Incremental Encoder UO-EM-FG 4

Power consumption	Max. 1 W through internal bus connection plus output load
connections	Internal bus connections
output	COMBICON – terminal strip
Number of pulses	1024 symmetrical square wave pulses
Signal hight	HTL (12 ... 30) V or 5 V to RS 422
Rated load each	50 mA (Ri = 50 Ohm)
Max. frequency	100 kHz
Equipped with the following options	1. Option (90°) 90 dgr. phase displacement to basic pulse 2. Option (N) reference pulse, mechanically fixed 3. Option (G) inverted signals
Connection diagram	EL 671a
Temperature range	-25 up to +70 °C

Dimension drawing

A = 114,50 mm B = 22,50 mm

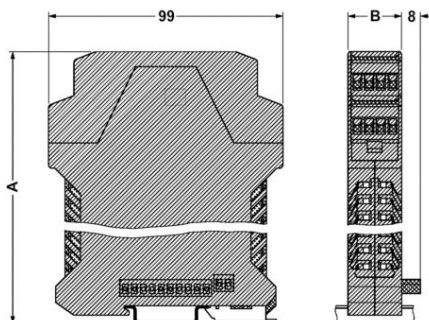

connection diagram

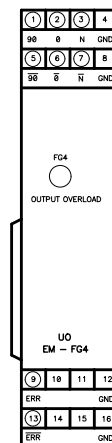

Pin	Signal	Waveform	Output
1	90 GRAD	[Square wave]	AUSGANG OUTPUT
2	0 GRAD	[Square wave]	
3	MARKER	[Pulse]	
4	GND	[Ground]	5 V
5	90 GRAD	[Square wave]	
6	0 GRAD	[Square wave]	
7	MARKER	[Pulse]	12...30V
8	GND	[Ground]	
9	FG CHECK	[Ground]	
10	NC		5 V
11	NC		
12	GND	[Ground]	
13	FG CHECK	[Ground]	12...30V
14	NC		
15	NC		
16	GND	[Ground]	

3.2.4 Electronic Module Electronic Overspeed Switch UO-EM-EGS 4

Power consumption	Max. 3 W through internal bus connection			
Connections	Internal bus connections			
Output	COMBICON – terminal strip			
Switching speed	2 programmable switching points (N/O)			
Switching voltage	Max. 250 V / AC / DC / max. 0,5 A			
Connection diagram	EL 669a			
Temperature range	-25 up to +70 °C			
Switching speed ranges Specify on order	min.	max.	min.	max.
	0,63 min ⁻¹	300 min ⁻¹	5 min ⁻¹	2400 min ⁻¹
	2,5 min ⁻¹	1200 min ⁻¹	10 min ⁻¹	3000 min ⁻¹

Programmable functions :

- Password secured/user administration
- Online-/simulation mode
- Reading and saving data
- Lock-/unlock function
- Trip delay time
- Rotational direction dependent switching
- Switching test
- Monitoring

Programming by decoder interface

Dimension drawing

A = 114,50 mm B = 35,00 mm

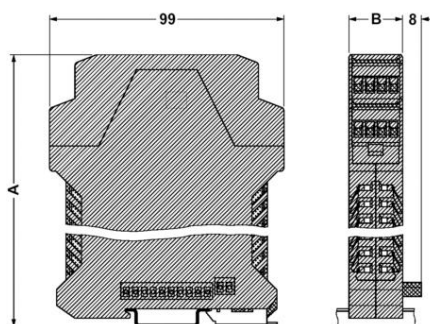

connection diagram

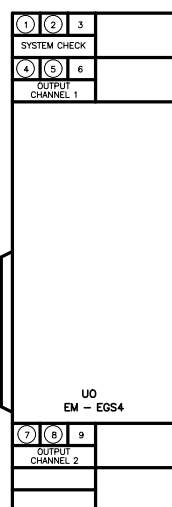

Anschlussplan / connection diagram EL669a	AUSGANG / OUTPUT
1 SYSTEM CHECK SYSTEM CHECK	1 — 2 Max. 230V AC/DC 0.5 A
2 SYSTEM CHECK SYSTEM CHECK	
3 NC	
4 SCHALTAUSGANG 1 OUTPUT CHANNEL 1	4 — 5 Max. 230V AC/DC 0.5 A
5 SCHALTAUSGANG 1 OUTPUT CHANNEL 1	
6 NC	7 — 8 Max. 230V AC/DC 0.5 A
7 SCHALTAUSGANG 2 OUTPUT CHANNEL 2	
8 SCHALTAUSGANG 2 OUTPUT CHANNEL 2	
9 NC	

3.2.5 Electronic Module Absolute Encoder CAN-Bus interface UO-EM-AMC

Power consumption	max. 1,5 W through internal bus connection
Connections	internal bus connections
Output	COMBICON – terminal strip
Resolution	12 Bit (4096 rev) / 12 Bit (4096 steps/rev.)
Connection diagram	EL 670a
Temperature range	-25 up to +70 °C
CAN-BUS interface	
Data interface	CAN-H, CAN-L, CAN-GND
Baud rates	(20-50-100-125-250-500-800-1000) kBaud
Device address	adjustable 0 – 96
CAN-operation mode	Polled Mode / Cyclic Mode / Sync Mode
Programmable parameter	Counting direction Preset value Total resolution Lower limit contact Upper limit contact

Dimension drawing

A = 114,50 mm

B = 22,50 mm

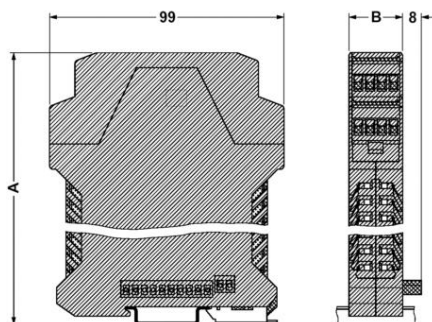

connection diagram

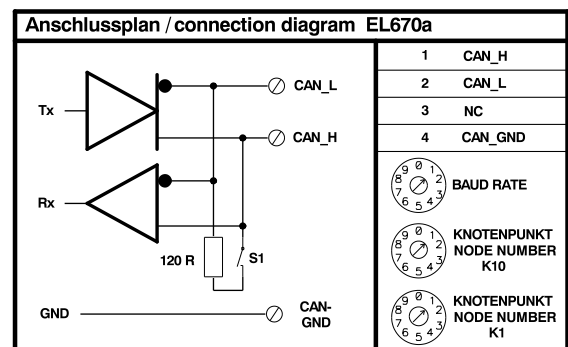
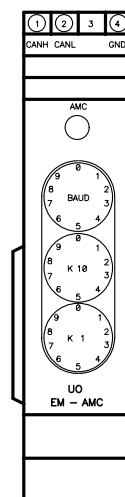

3.2.6 Electronic Module Absolute Encoder PROFI-Bus interface UO-EM-AMP

Power consumption	Max. 6 W through internal bus connection
Connections	Internal bus connections
Output	D-Sub terminal female
Resolution	12 Bit (4096 rev.) 12 Bit (4096 steps/rev.)
Connection diagram	EL 722b
Temperature range	-25 uo to +70 °C
PROFIBUS-DP interface	
Data interface	RS 485,electrically insulated from encoder electronics (12-6-3-1,5) Mbaud (500-187,5-93,75-19,2-9,6) Kbaud
Device address	Adjustable 0-99
Bus termination	Switchable
Programmable functions	
Multiturn or Singleturn Class 1 mode Class 2 mode (see programming manual)	Counting direction Counting direction Resolution/rev. Total resolution Scaling
Mode 2.1	Class 2 mode with additional end switch function
Mode 2.2	Class 2 mode with additional end switch function and velocity output

Dimension drawing

A = 114,50 mm B = 44,00 mm

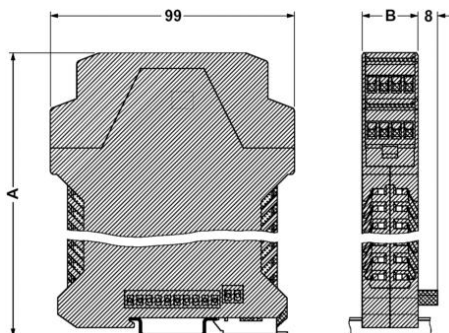

connection diagram

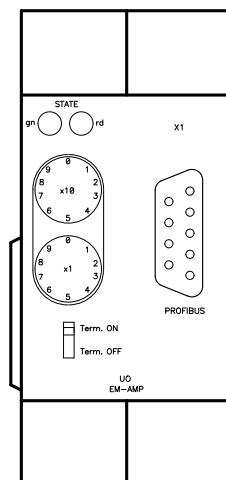

EL 722 b

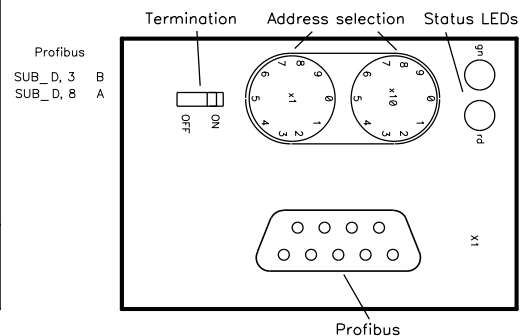

3.2.7 Electronic Module Absolute Encoder Multiturn with SSI-interface UO-EM-AMS

Power consumption	Max. 1 W through internal bus connection
Connections	Internal bus connections
Output	COMBICON – terminal strip
Resolution	12 Bit (4096 rev.) 12 Bit (4096 steps/rev.)
Connection diagram	PN 702a
Temperature range	-25 up to +70 °C
Interface SSI	
Data interface	SSI – clock, SSI - data
Clock frequency	max. 1 MHz
Timeout	28 µs
Hardware inputs	Counting direction Preset selection Preset set
U-ONE programming interface	
Programmable parameter (see programming manual)	Preset value 1 Preset value 2 Output format

Dimension drawing

A = 114,50 mm

B = 22,50 mm

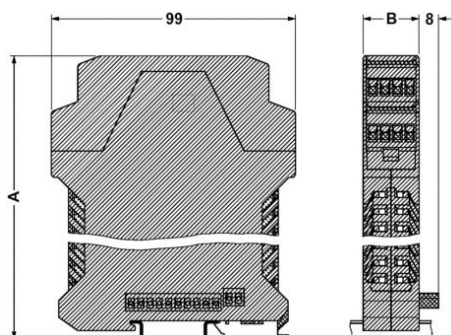

connection diagram

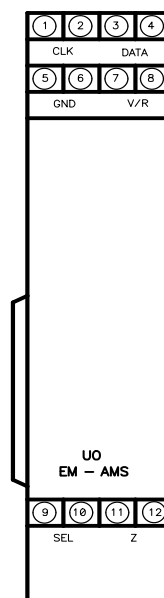

Pin	Signal	Symbol	Description
1	CLOCK +	[Symbol]	EINGANG / INPUT RS422
2	CLOCK -	[Symbol]	EINGANG / INPUT RS422
3	DATA +	[Symbol]	AUSGANG / OUTPUT RS422
4	DATA -	[Symbol]	AUSGANG / OUTPUT RS422
5	GND SSI	[Symbol]	GND
6	GND SSI	[Symbol]	GND
7	V/R +	[Symbol]	EINGANG / INPUT 12..30V
8	V/R -	[Symbol]	EINGANG / INPUT 12..30V
9	SEL +	[Symbol]	EINGANG / INPUT 12..30V
10	SEL -	[Symbol]	EINGANG / INPUT 12..30V
11	Z +	[Symbol]	EINGANG / INPUT 12..30V
12	Z -	[Symbol]	EINGANG / INPUT 12..30V

3.2.8 Electronic Module Absolute Encoder Multiturn, with Ethernet-interface UO-EM-AME/M

Power consumption	Max. 1 W through internal bus connection
output	RJ-45 connector
Resolution	12 Bit (4096 rev.) 12 Bit (4096 steps/rev.)
Connection diagram	PN 110-400
Temperature range	-25 up to +70 °C
Interface Ethernet	
Data interface	RJ-45 connector
Baud rates	10/100 Mbit autodetect
Protocol	Modbus over TCP/IP
Programmable parameter	
(see programming manual)	Counting direction Preset value Lower limit contact Upper limit contact
U-ONE programming interface	
Programmable parameter	ERC-functions IP-Address Subnet mask Default gateway

Dimension drawing

A = 114,50 mm

B = 22,50 mm

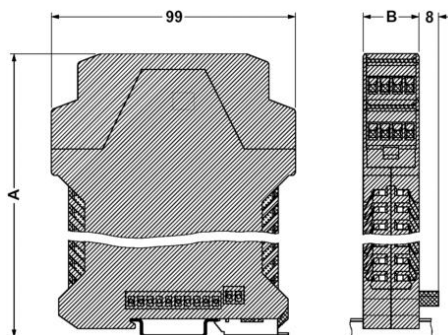

connection diagram

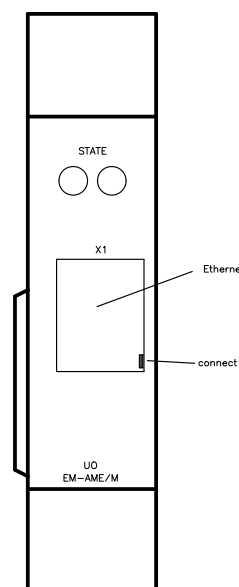

PN 110 - 400

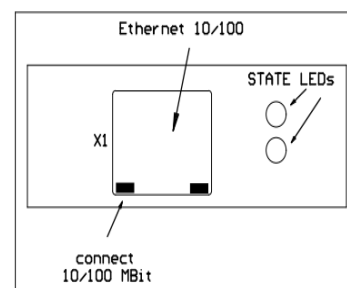

3.2.9 Electronic Module Position Switch UO-EM-ERC

Power consumption	max. 6 W through internal bus connection
Connections	Internal bus connections
Switching position (see programming manual)	6 programmable switching points, relais contacts (change over) 250 V (AC), 500 mA, 30 W 1 error signal Relais contact (nc)
Switching voltage	Max. 250 V / AC / DC / max. 0,5 A
Connection diagram	EL 723 a
Temperature range	-25 up to +70 °C

Programmable functions :

- Bit number in multiturn operation
- Selection Single / Multiturn
- Switching range input/can be converted
- Value of hysteresis
- Counting direction
- Dimensional unity
- identification
- Last edit (automatic setting)
- Conversion factor

Programming by decoder interface / EL 723a

Dimension drawing

A = 114,50 mm B = 45,00 mm

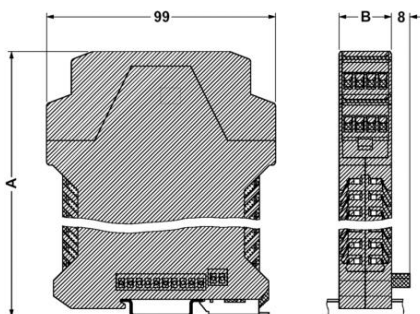

connection diagram

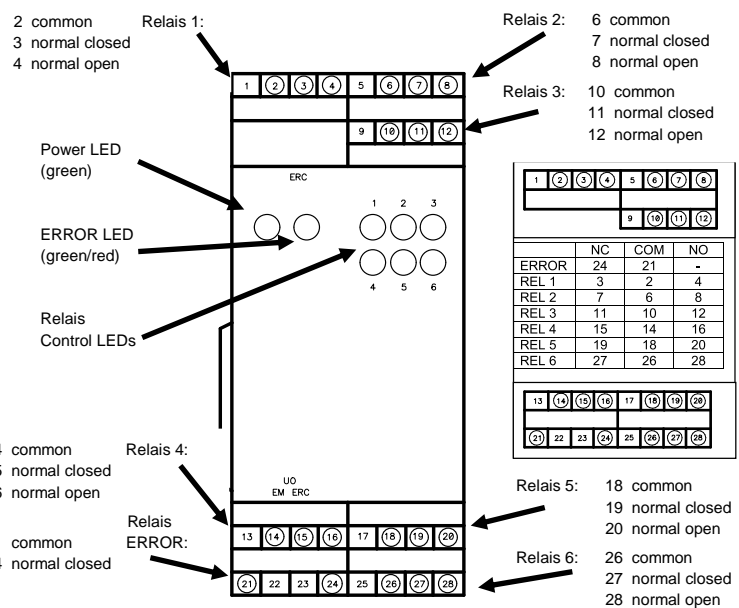

4 Transport, packaging, and storage

4.1 Instructions for transport

Improper transport



CAUTION!

Improper transport can cause property damage!

Comply with the symbols and warnings on the packaging.

- Handle with care
- Protect from moisture
- Protect from heat over 40°C and direct sunlight

4.2 Incoming goods inspection

Check delivery immediately upon receipt for completeness and possible transport damage.

Inform the forwarder directly on receipt of the goods about existing transport damages (prepare pictures for evidence).

4.3 Symbols on the packaging



Protect from moisture

Keep packed goods dry and protected against moisture.

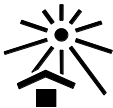

Protect from heat

Protect packaged goods from heat over 40°C and direct sunlight.

4.4 Transport inspection

Check delivery immediately upon receipt for completeness and possible transport damage.

4.5 Packaging

Handling packaging materials

The packaging is not taken back and must be disposed of in accordance with the respective statutory regulations and local guidelines.

Storage of packed goods

- Store in a dry and dust-free location.
- If stored for longer periods (> 6 months) we recommend sealing the devices in foil, possibly with a desiccant.
- Do not expose to aggressive media.
- Storage temperature: - 15 °C ... +40 °C.
- For storage periods longer than 6 months: Contact the manufacturer.

5 Installation and commissioning

5.1 Safety instructions



Personnel

The installation and start-up should only be performed by qualified personnel for this kind of work.

Warning : Before starting any work (installation / maintenance) on the device it is necessary to strictly observe the safety instructions in Chapter 2

5.2 Mounting of the basic unit (mechanically)



Note:

Using a hammer, or a similar tool, to attend the assembly or disassembly is prohibited (loss of validity of guarantee).

Before installing the base unit, please lightly lubricate the shaft.

Always grease the shaft slightly before mounting.

Encoder in flange construction B5 have to be fixed with 4 to 6 screws (M6x20) equally spaced on the Circumference on the flange.
Screws required M6x20-8.8 (eg. ISO 4017)

Encoder in foot construction B35 have to be fixed with 4 screws M6 at the foot, screw – in depth min.12 mm
Screws required M6x20-8.8 (eg. ISO 4017)

Attention: Mounting surface of the foot and the base must be clean and even.

Encoder with spacer flange and coupling.
See mounting instructions No. 45 690 for couplings.

This mounting manual is provided with the order by Accessories (coupling) separately.

5.3 Mounting of the basic unit / Modules

5.3.1 Mounting of the Basic unit

To protect the device during transport and storage the gland screw is blocked by a plastic cap. This must be removed before mounting.

Connection :

Connection according to connection diagram EL 667 (see chapter 3).

The connection diagrams are to observe strictly!

See chapter 3 and in the terminal box.

To ensure the degree of protection , a cable section min. 8,5 up to max. 10 mm must be used.

Attention: The spring contacts of the strip must be handled with care.

The ST connector must be introduced with care and it is necessary to pay attention to coding.



NOTES!

Wiring and shielding:

(Measurement of electromagnetic compatibility).

The power cable must be installed with a minimum distance of 20 cm compared to other drivers if they drive a voltage above 60 V !

Cable gland :

If only one gland is used, it must be checked that the cap on the other side is fixed properly.

Closing the terminal box :

Check if the seal is clean or do cleaning. Then put the terminal box cover properly and secure it.

Beware when the terminal box is open :

During the connection of the power cable moisture may not enter into the interior of the terminal box.

5.3.2 Mounting the modules

Snap modules on the top hat and push them into position.

Attention :

When the locking and positioning of the modules, it is very important to pay attention to avoid deterioration of the contact pins.

You have to put the modules to ensure the smooth operation of the contacts.

The supplied covers must be mounted on both ends.

The connection diagrams are strictly to observe :

See chapter 3 and on the modules housing.

6 Disassembly

6.1 Safety tips



Personnel

The disassembly should only be performed by qualified personnel for this kind of work.
Warning :Before starting any work (installation / maintenance/disassembly) on the device it is necessary to strictly observe the safety instructions in Chapter 2

6.2 Disassembly

Basic unit

The dismantling of the basic unit is made in the reverse order of assembly as described.

Modules

Separate modules unit the connection is completely disconnected side. Then remove the module from the top hat.

7 Troubles

Disturbance	Possible cause	Remedy
Table of disruptions of Dasic device		
Shaft rotation lasts	Bearing defective	Contact Customer Service Hübner
Rotating shaft noisy	Bearing defective	Contact Customer Service Hübner
Intrusion of moisture into the terminal box (see also in chapter 2)	Terminal box seal defective	Contact Customer Service Hübner
	Cable gland	Verification by specialist
	Cable section inadequate	Adjust the screw grommet in the cable section
Table disturbances modules		
Decoder D2		
DEL "PWR" OFF	No power supply	Check voltage
DEL "READY" OFF	Fibre optic cables 1 and 2 inverts	Invert the position fibre optic cables
	No power supply to the Basic unit	Check the power supply of the Basic unit
	Fibre optic cable defective	Exchange the fibre optic cable
	Basic unit defective	Contact Customer Service Hübner
	Module D2 defective	Contact Customer Service Hübner

Module FG 4		
LED lights	Short-circuit on a cable	Remove short-circuit
Module AMC		
LED glows red	Like « READY LED » OFF	
	Absolute values are inconsistent	Shut down and restart the equipment. If the problem persists, contact Customer Service Hübner
Module EGS4		
No function	Various	Computer diagnostic
Module AMP		
No LED lit	No reception of absolute values	Like « READY LED » OFF
Module ERC		
LED glows red	Like « READY LED » OFF	
	Various	Computer diagnostic
Module AME/M		
	Like « READY LED » OFF	
	Various	Computer diagnostic
Module AMS		
LED glows red	Like « READY LED » OFF	
	Various	Computer diagnostic

8 Maintenance

8.1 Safety tips



Personnel

The maintenance should only be performed by qualified personnel for this kind of work.
 Warning :Before starting any work (installation / maintenance/disassembly) on the device it is necessary to strictly observe the safety instructions in Chapter 2

8.2 Maintenance

The Basic unit requires no maintenance. However, it is recommended to perform the following verifications to ensure smooth operation without disruption.

8.3 Inspection Plan

Intervals	Verification	Execution
Every 12 month	Blocage des vis de fixation	Verification by specialist
Every 12 month	Tightness of the screws	Verification by specialist
After approx. 16 000 to 24 000 hours of operation and continues load	Examination of ball bearings in rotating flexible and sounds possible	Verification by specialist
	Exchange of worn ball bearings only by the manufacturer	Contact Customer Service Hübner

9 Disposal

9.1 Disposal drain

The manufacturer is not obliged to take back used electronic components.

The device is classed as electronic equipment and subject to the WEEE Directive; observe local, country-specific laws when disposing of the device.

For information on environmentally sound disposal please contact your local authority or a specialist disposal company.

10 Declaration of Conformity

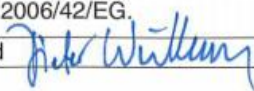
Declaration of Incorporation of partly completed machinery (EC Directive 2006/42/EG)		
<p>We the manufacturer Johannes Hübner Fabrik elektrischer Maschinen GmbH Siemensstrasse 7 D-35394 Giessen</p> <p>of the partly completed machine Product designation: Universal encoder U-ONE® Type designation: UOM 4L-1212</p> <p>The following essential health and safety requirements contained in Annex 1 of the above Directive have been applied and fulfilled. General Principles – No. 1</p> <ul style="list-style-type: none"> 1.1.2 The principles of safety integration 1.1.3 Materials and products 1.1.5 Design of machinery to facilitate its handling 1.3.2 Risk of break-up during operation 1.3.4 Risks due to surfaces, edges or angles 1.5.1 Electricity supply 1.5.9 Vibration 1.7.1 Information and warnings on the machinery 1.7.3 Marking of machinery <p>The requirements of the Directive 2006/95/EC regarding the safety objectives set out in Annex 1, sub section 1.5.1 Machinery Directive 2006/42/EC have been fulfilled.</p> <p>Electromagnetic compatibility (2004/1 08/EG)</p> <p>The following standards (or parts of) have been used:</p> <p>EN 12100-1 2003-11 Safety of machinery – Basic concepts, general principles for design. Part 1 Basic terminology, methodology</p> <p>EN 12100-2 2003-11 Safety of machinery – Basic concepts, general principles for design. Part 2 Technical principles and specifications</p> <p>DIN EN 60204-1 2006-06 Safety of machinery . Electrical equipment of machines Part 1: General requirements</p> <p>The relevant technical documentation has been drawn up in accordance with Annex VII B and will be transmitted electronically as EDP data to the competent authority upon request.</p> <p>CE Authorised representative Gerhard Esch QMD (Head of QM); address as above The partly completed machine must not be put into service until the machinery in which the aforementioned partly completed machine is to be incorporated has been declared in conformity with the provisions of the Machinery Directive 2006/42/EG.</p>		
Signed	 Dieter Wulkow for the Management	Date:16.09.2010

Declaration of Incorporation_U_ONE®_en_1

11 Intallation instructions for couplings



Montageanleitung für Kupplungen Mounting Instructions for Couplings

NR. 54 690 S.1

Datum: 06/2009

Kupplungsbohrung – Passung G7 oder H7 –
d. h.: Toleranzfeld liegt oberhalb der Nulllinie.
= Kupplung muß leichtgängig aufziehbar
sein =

Bohrungen vor der Endmontage prüfen evtl.
nachreiben, dann leicht einfetten.

Mindestens eine Nabe, mit Radialgewindestift
mit Spitze/Ringschneide, gegen
Axialverschiebung befestigen. Gewindestift
drückt auf Paßfeder, damit Welle nicht
beschädigt wird.

Beachte: **zulässige Nachgiebigkeiten!**
sind voneinander abhängig – siehe Rückseite

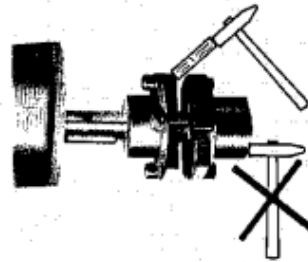

Coupling bore – fit – G7 or H7
i. e.: tolerance range is above the reference line
= Fit the coupling smoothly =

Please refinish coupling bores prior to final
mounting, if necessary finish-ream and grease
bores slightly.

Provide axial fastening on shaft by radial set
screw. Fasten at least one set screw with coned
point/cupped gripping point to avoid axial offset.
Set screw pushes onto the feather key to
prevent shaft from damage.

Note: **admissible resiliances!**
are dependent on each other see backside

Anbaufehler:

- bewirken Radialkräfte, diese können die Geberlager und die Kupplung beschädigen oder zerstören!
- Verschlechtern Signalqualität! Verstärkt Oberwelligkeit und Drehschwung!

Je genauer der Anbau, um so höher die Lebensdauer der Kupplung/Geberlager, um so präziser die Ausgangssignale!

Mounting fellures!

- Misalignment can cause radial forces which may damage the coupling or destroy the encoder bearings!
- Signal quality can be affected, rotational frequency modulation and Interferences (ripple) may occur.

The more precise the mounting, the higher the service life of the coupling and the bearings of the encoders.

Kupplung Typ HK.. 5-

durch Deformation bei Montage, beim Überschreiten der zulässigen Nachgiebigkeiten kann der Federstahl-Ausgleichsring Ø 54 mm beschädigt werden.



Coupling Type HK.. 5-

by deformation caused by wrong mounting and if permissible resiliances will be exceeded, spring steel compensating element dia 54 mm can be damaged.

Balgkupplungen Typ EK.. / DKN..:

Bei der Montage/Demontage kritisch
– Bruchgefahr des Faltenbalgtes – vor allem bei der Demontage feststehender Wellenzapfen.

Verwendung von rostlösendem Gleitspray o.ä., Radialgewindestrauben vorher lösen. Kupplung vorsichtig an den Naben abdrücken. Reservekupplung einplanen.



Metal bellows coupling type EK/DKN..

Critical fitting/removal

Bellows may brake above all while removing from the tight shaft extension.

For removal it is recommended to use an antirust/ anticorrosion spray and to unscrew the radial set screw. Press on the hubs carefully when removing the coupling. Spare coupling should be available

Steckkupplungen Typ HK7-HK45:

Bei der Montage ist die axiale Lage der Kupplungshälften zu beachten, ein ausreichender Abstand von 1 – 2 mm zum Kunststoffstern sind einzuhalten, damit dieser nicht gequetscht wird und die elektrische Isolierung erhalten bleibt. Abstandsverhältnisse müssen ausgemessen werden, damit keine zusätzliche axiale Verspannkraft entsteht, die sich sehr nachteilig auf die Lagerlaufzeit und auf die Ausgangssignale auswirkt!



Push-on coupling HK7 up to HK 45

For mounting please consider axial position of coupling halves. A distance of 1 – 2 mm to the Plastic tooth ring must be maintained in order to prevent it from squeezing and to protect the electrical insulation. Distance relation of coupling parts must be measured to avoid axial forces affecting both the service life of the bearings and the output signals!

12 Index

C

Copyright	6
Customer service	6

D

Declaration of Conformity	26
Directory	3
Disassembly	23
Disclaimer	6
Disposal	25

E

Electrical and mechanical data	9
Electrical current	8
Electronic Module Absolute Encoder CAN-Bus interface UO-EM-AMC	15
Electronic Module Absolute Encoder Multiturn with SSI-interface UO-EM-AMS	17
Electronic Module Absolute Encoder Multiturn, with Ethernet-interface UO-EM-AME/M	18
Electronic Module Absolute Encoder PROFI-Bus interface UO-EM-AMP	16
Electronic Module Electronic Overspeed Switch UO-EM-EGS 4	14
Electronic Module Incremental Encoder UO-EM-FG 4	13
Explanation of symbols	5

F

Fiber optic decoder UO-EM-D2 / for decoding the optical (fibre optic) signals of the basic unit and supply of electronic function modules	12
---	----

G

General	5
Guarantee terms	6

I

Incoming goods inspection	20
Index	28

Information about the Operating and Assembly

Instructions	5
Inspection Plan	25
Installation and commissioning	21
Instruction for transport	20
Intallation instructions for couplings	27
Intended use	6

M

Maintenance	25
Mounting of the Basic unit	22
Mounting of the Basic unit (mechanically)	21
Mounting of the Basic unit / Modules	22
Mounting the modules	22

N

Non intended use	7
------------------------	---

P

Packaging	20
Personal protective equipment	7

R

Responsibility of the owner	6
Rotating shafts	8

S

Safeguarding against restart	8
Safety	6
Safety instructions	21
Safety tips	23, 25
Scope of delivery	5
Special dangers	8
Symbols on the packaging	20

T

Technical data	9
Transport inspection	20
Transport, packaging, and storage	20
Troubles	23
Type plate	9