

(Assembly) Instructions

D.C. tachometer generator

TDP 0,7

**Read the (assembly) instructions prior to
assembly, starting installation and handling!
Keep for future using!**



Brand names and product names are trademarks or registered trademarks of their respective owner. Protected trademarks bearing a TM or ® symbol are not always depicted as such in the manual. However, the statutory rights of the respective owners remain unaffected.

Manufacturer / publisher

Johannes Hübner
Fabrik elektrischer Maschinen GmbH, Giessen
Siemensstraße 7
35394 Giessen
Germany
Phone: +49 (0) 641 / 7969-0
Fax: +49 (0) 641 / 73645
E-Mail: info@huebner-giessen.com
Internet: www.huebner-giessen.com
Headquarters: Giessen
Court of registration: Giessen
Commercial register number: HRB 126
Joint Managing Directors: Dieter Wulkow
Oliver Rüspeler

The manual has been drawn up with the utmost care and attention. Nevertheless, we cannot exclude the possibility of errors in form and content. It is strictly forbidden to reproduce this publication or parts of this publication in any form or by any means without the prior written permission of Johannes Hübner – Fabrik elektrischer Maschinen GmbH.
Subject to errors and changes due to technical improvements.

Published January 2011

Copyright © Johannes Hübner – Fabrik elektrischer Maschinen GmbH, Giessen.
All rights reserved.

Directory

1	General	5
1.1	Information about the (assembly) instructions	5
1.2	Scope of delivery	5
1.3	Explanation of symbols	5
1.4	Disclaimer.....	6
1.5	Copyright	6
1.6	Guarantee terms	6
1.7	Customer service	6
2	Safety	7
2.1	Responsibility of the owner	7
2.2	Intended use	7
2.3	Improper use	7
2.4	Personal protective equipment.....	7
2.5	Personell	7
2.6	Special dangers	7
2.6.1	Electrical current	8
2.6.2	Rotating shafts and hot surfaces.....	8
2.6.3	Ensure the power supply cannot be reconnected	8
3	Technical Data	9
3.1	Type plate	9
3.2	Type key	10
3.3	Technical Data.....	10
3.3.1	Dimensions, Power consumption, Environment, Speed	10
3.3.2	Elektrical and mechanical data.....	11
3.3.3	General technical data	12
4	Construction and Function	14
4.1	Block diagram.....	14
4.2	Short description.....	14
4.3	Connections	14
5	Transport, packaging and storage	15
5.1	Safety instructions for transport	15
5.2	Incoming goods inspection.....	15
5.3	Packaging (disposal).....	15
5.4	Storage of packages (devices)	15
5.5	Uses	16
5.6	Place of installation	16
5.7	Installation work	17
5.7.1	Installation and commissioning.....	17
5.8	Dismantling	19
6	Disorders	20
6.1	Diagnosis Chart	20
6.2	Inspection and maintenance schedule.....	22
7	Disposal.....	24
7.1	Disposal procedure	24

8	Spare parts	24
9	Annex	24
9.1	Connection diagram.....	24
10	Dimension drawings	25
10.1	Screw tightening torques.....	31
11	EC- Declaration of Incorporation	32

1 General

1.1 Information about the (assembly) instructions

These (assembly) instructions provide important instructions for working with the device. They must be carefully read prior to starting all tasks, and the instructions contained herein must be followed. In addition, applicable local regulations for the prevention of industrial accidents and general safety regulations must be complied with.

1.2 Scope of delivery

Scope of delivery includes the D.C. tachometer generator TDP 0,7 and the (assembly) Instructions.

1.3 Explanation of symbols

Warnings are indicated by symbols in these (assembly) instructions. The warnings are introduced by signal words that express the scope of the hazard.

The warnings must be strictly heeded; you must act prudently to prevent accidents, personal injury, and property damage.



WARNING!

Indicates a possibly dangerous situation that can result in death or serious injury if it is not avoided.



CAUTION!

Indicates a possibly dangerous situation that can result in minor injury if it is not avoided.



CAUTION!

Indicates a possibly dangerous situation that can result in material damage if it is not avoided.



NOTE!

Indicates useful tips and recommendations as well as information for efficient and trouble-free operation.

Special safety note:



DANGER!

Life-threatening danger due to electric shock!

Indicates a life-threatening situation due to electric shock. If the safety instructions are not complied with there is danger of serious injury or death. The work that must be executed should only be performed by a qualified electrician.

1.4 Disclaimer

All information and instructions in these (assembly) instructions have been provided under due consideration of applicable guidelines, as well as our many years of experience.

The manufacturer assumes no liability for damages due to:

- Failure to follow the instructions in the (assembly) instructions
- Non-intended use
- Deployment of untrained personnel
- Opening of the device or conversions of the device

In all other aspects the obligations agreed in the delivery contract as well as the delivery conditions of the manufacturer apply.

1.5 Copyright



NOTE!

Content information, text, drawings, graphics, and other representations are protected by copyright and are subject to commercial property rights. It is strictly forbidden to make copies of any kind or by any means for any purpose other than in conjunction with using the device without the prior written agreement of the manufacturer. Any copyright infringements will be prosecuted.

1.6 Guarantee terms

The guarantee terms are provided in the manufacturer's terms and conditions.

1.7 Customer service

For technical information personnel is available that can be reached per telephone, fax or email. See manufacturer's address on page 2.

2 Safety



This section provides an overview of all the important safety aspects that ensure protection of personnel, as well as safe and trouble-free device operation. If these safety instructions are not complied with significant hazard can occur.

2.1 Responsibility of the owner

The device is used in commercial applications. Consequently the owner of the device is subject to the legal occupational safety obligations, and subject to the safety, accident prevention, and environmental protection regulations that are applicable for the device's area of implementation.

2.2 Intended use

The device has been designed and constructed exclusively for the intended use described here.

Series TDP 0,7 are used for speed monitoring, for instance of electrical and mechanical drives, hoisting gear, and conveying machines.

Claims of any type due to damage arising from non-intended use are excluded; the owner bears sole responsibility for non-intended use.

2.3 Improper use

- Do not use the device in potentially explosive areas.
- The device must not be subjected to mechanical loads in addition to its own weight and unavoidable vibration and shock loads that arise during normal operations.

Examples for non-permitted mechanical loads (incomplete list):

- Fastening transport or lifting tackle to the device, for example a crane hook to lift a motor.
 - Fastening packaging components to the device, for example ratchet straps, tarpaulins etc.
 - Using the device as a step, for example by people to climb onto a motor.
- It is not permitted to use the device in locations higher than 1000 m above sea level.

2.4 Personal protective equipment

Wear personal protective equipment such as safety shoes and safety clothing to minimise risks to health and safety when carrying out work such as installation, disassembly or commissioning. Adhere to all applicable statutory regulations as well as the rules and standards determined by the owner.

2.5 Personell

Installation and commissioning as well as disassembly routines must be carried out by skilled technical staff only.

2.6 Special dangers

Residual risks that have been determined based on a risk analysis are cited below.

2.6.1 Electrical current



Danger of death from electricity!

There is an immediate danger of death from contact with live components. Damage to the insulation or individual components can be lethal.

Therefore: If the insulation is damaged turn off and isolate the power supply immediately; ensure the insulation is repaired. Before commencing any work on the electrical installation turn off and isolate the power supply to the installation. Ensure live components do not come into contact with moisture. Otherwise, this can lead to a short-circuit.

2.6.2 Rotating shafts and hot surfaces



WARNING!

Risk of injury from rotating shafts!

Touching rotating shafts can result in serious injuries.

Therefore: Do not tinker with moving parts/shafts or work on rotating shafts. Do not open covers during operations. Ensure no parts are moving before opening any covers. The encoder can become very hot when operated for longer periods of time. There is a risk of burns on contact!

2.6.3 Ensure the power supply cannot be reconnected



DANGER!

Danger of death from unauthorized reconnection of the power supply!

There is a risk that the power supply will be reconnected without authorization when carrying out work, for example when rectifying faults. This represents a serious risk to the life of those in the danger zone.

Therefore: Turn off and isolate all power supplies to the equipment before commencing work. Ensure the power supplies cannot be reconnected.

3 Technical Data

3.1 Type plate

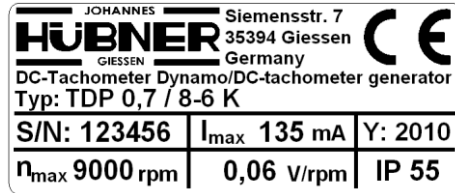

Fig. 1 type plate

The type plate is located on the side of the housing and contains the following information:

- Manufacturer, address
- CE mark
- S/N = Serial number
- Y = year of construction
- Rated voltage (DC) [V] / rated speed [rpm]
- I_{max} = maximum current [mA]
- n_{max} = maximum speed [rpm]
- IP = degree of protection

Electrical design to VDE 0530

Please note: The details on the nameplate apply exclusively to a purely resistive load. The details differ for inductive or capacitive loads (please consult the manufacturer).

3.2 Type key

TDP 0,7 /8 – 15 SE spec. (Example) + FSE 102 overspeed switch (Optional)

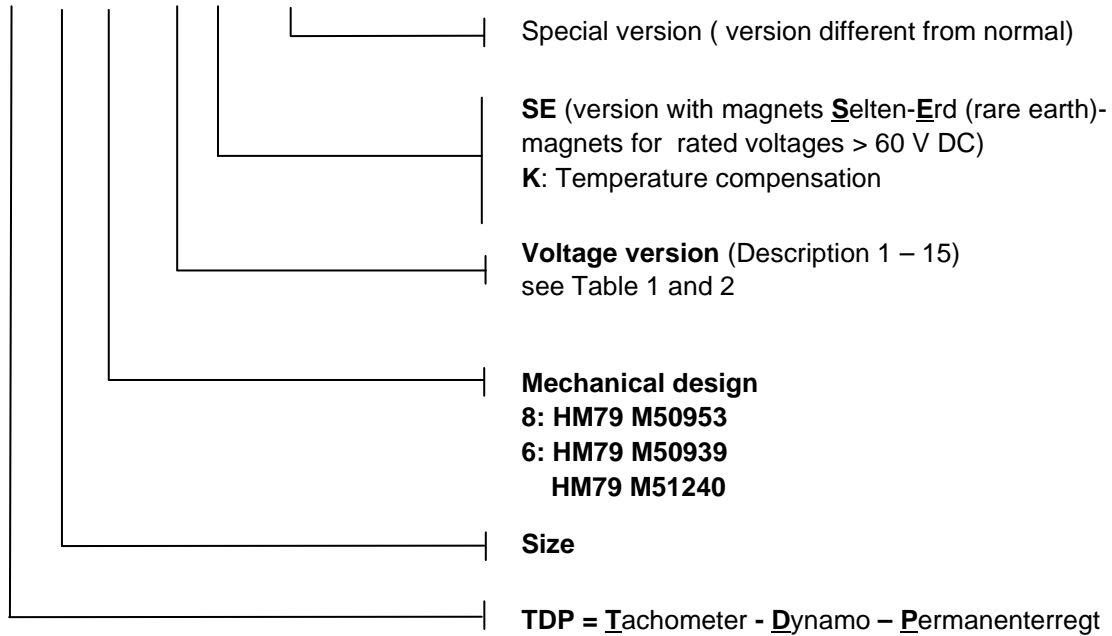

3.3 Technical Data

3.3.1 Dimensions, Power consumption, Environment, Speed

Indication	Value	Unit
Weight	See chapter 10 dimension drawings /mechanical data	kg
Dimensions	See chapter 10 dimension drawings /mechanical data	mm
Open circuit voltage (DC)	Factor 1,05 to rated voltage/rpm see label on machine	V DC/rpm
Rated voltage with load (DC)	See label on machine	V DC/rpm
Maximum rated current	See label on machine	A DC
Machine-Temperature range	- 40 up to + 100	°C
Maximum speed	See label on machine	rpm

3.3.2 Elektrical and mechanical data

Table 1: (Standard series)

TYPE	Rated voltage at 1000 rpm	Max. speed**	Max. permissible current at 1000/9000 rpm	Optimum load resistance	Armature-resistance at 20 ° C	No load-voltage at 1000 rpm
	[V]	[rpm]	[mA]	[k Ω]	[Ω]	[V]
TDP 0,7/...-1	10	9000	90/810	1,1	5,4	10,5
TDP 0,7/...-2	20	9000	45/405	4,4	21	21
TDP 0,7/...-3	30	9000	30/270	10	44	31,3
TDP 0,7/...-4	40	9009	22/198	18	93	42
TDP 0,7/...-5	50	9000	18/162	28	128	52
TDP 0,71...-6*	60	9000	15/135	40	180	63

Table 2: (SE Series)

TYPE	Voltage at 1000 rpm	Maximum speed	Minimum-load-resistance	Armature-resistance at 20 ° C	Current
	Volt	rpm	Ohm	Ohm	mA
TDP 0,7 ...7-SE	70	7700	1200	47	57
TDP 0,7 ...8-SE	80	6750	1600	61	50
TDP 0,7 ... 9-SE	90	6000	2000	58	44
TDP 0,7 ..10-SE	100	5400	2500	95	40
TDP 0,7 ..11-SE	110	4900	3000	115	36
TDP 0,7 ..12-SE	120	4500	3600	138	33
TDP 0,7 ..13-SE.	130	4150	4200	161	31
TDP 0,7 ..14-SE	140	3850	4800	187	29
TDP 0,7 ..15-SE	150	3600	5600	215	27

3.3.3 General technical data

General Information

Magnetic system - external field influence

The magnetic system of this machine consists of two permanent block magnets made from an AlNiCo alloy specially developed for this machine. The direction of magnetisation is determined by the preferred magnetic orientation.

To guarantee non-ageing operation the permanent magnets are artificially aged until they reach their optimum remanent density of magnetic energy. Avoid short-circuits because of the unfavourable effects on the commutator; any burnouts can lead to additional harmonics.

Magnetisation - external field influence

To prevent voltage loss **ensure the magnetic circuit of the machine is not interrupted after magnetising.**

Insulation

Insulation class B

Voltage

The listed voltages are detailed in the technical tables. Intermediate values and special voltages are optional (Option).

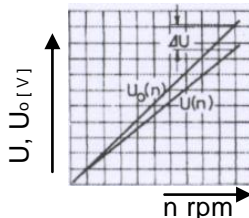

Speed / voltage characteristic

Terminal connection - polarity

Connecting a two-pole terminal board. When operating the machine in a **clockwise direction** (viewing the shaft end) the **Ai terminal is positive** and the **AU terminal is negative**.

Carbon brushes / brush holders

The dimensional design and quality of the silver-graphite **carbon brushes guarantee a long service life and maintenance-free operations**. The service life of the carbon brushes depends to a large extent on the condition of the circulating air and the peripheral speed. Under normal operating conditions the service life is approx. 15 000 operating hours.

Suitable, solid double-type brush holders with increased brush pressure (600 cN/cm²) for DC tachogenerators subjected to vibration and shock loads.

Temperature compensation

There is a reduction in voltage when the temperature increases as a consequence of the temperature course of the permanent magnet as well as an increase in the internal resistance of the windings. It is possible to compensate the **temperature course** of the permanent magnet to a **tolerance of $\pm 0.5\%$ per 10 K in the temperature range 0 to +100 °C** (Option).

Harmonics

A low percentage harmonic content (distortion) across a large speed range is a significant characteristic of a good tacho voltage. The r.m.s. value of the overall mix of harmonics is generally measured using a thermionic voltmeter and considered in relation to the DC voltage.

This value is approx. **3‰ at a speed between 100 to 3000 rpm**.

Machine related harmonics result from the construction, electrical design and utilisation as well as production asymmetries.

Assembly related harmonics (single and double speed frequency) are caused by **angular misalignment and parallel displacement**.

Ensure **precisely centred assembly**, in particular in conjunction with B 3.

Align added device referring to a harmonics oscillogram (<5‰).

Linearity

The suitability of a tacho-generator for widely varying control tasks is determined by the linear relationship between the output voltage and speed.

Optimum load current and armature reaction

The max. permissible load current for the respective machine type is detailed in the table, which with the linearity error should not be exceeded.

Linearity error values can reach 5‰ if the tacho-generator is operated at max. current loads. For very precise control tasks of applications requiring a speed deviation range of 1‰ it is recommended to choose the value detailed in the table for **optimum load resistance** as terminal resistance. These relatively high ohmic terminal resistances ensure that just 1/10 of the maximum current is allowed to flow. As a consequence, the armature reaction, which acts as the flux-weakening component when higher currents flow, will be weakened by a factor of 10. This in turn means there will be no noticeable field distortion resulting from armature reaction.

Brush contact voltage

DC tacho-generators are generally fitted with silver-graphite carbon brushes, which exhibit a very low brush contact voltage. The total voltage drop at the sliding contact of the carbon brush/commutator depends on the peripheral speed, current density below the brushes, brush pressure and the characteristic build-up of patina on the brush contact surface.

Degree of protection to DIN VDE 0530 Part 5

This machine is designed to degree of protection IP 55, is completely enclosed and protected against low pressure jets of water from all directions and the build-up of harmful deposits of dust.

Special degree of protection IP 56 when the shaft is sealed with an axial sealing ring (extra charge). Max. speed 4000 rpm.

Shaft ends - shaft seals

The cylindrical shaft ends with Ø11 are machined with a closed keyway to DIN 6885 Blatt 1 (key included in scope of supply). Special shafts with Ø7 and Ø6 available.

It is possible to seal all tacho-generators with a **sealing ring** on the **drive side**; this is generally fitted when adding a speed increasing gear.

Bearings

All designs are equipped with sealed and lubricated for life deep groove ball bearings.

Design Fixed bearing DS (drive side)

B 3, B 5 6201 LLU

Coating - surface protection

Light-grey coating RAL 7030.

In addition to special insulation an appropriate protective coating is applied to tacho-generators exposed to aggressive gases and vapours.

Accessories

To maintain the **degree of protection** class rating **IP 55 and IP 56** we use **skin-tight** cable glands SR-1109 Pg 11 for connection cables Ø 7.5-9 mm.

4 Construction and Function

4.1 Block diagram

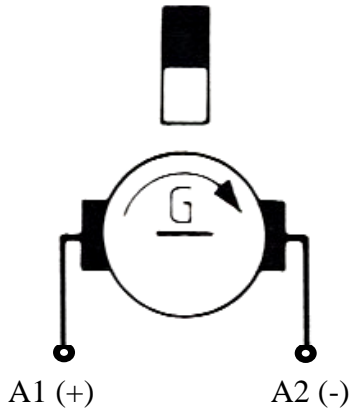

Fig. 2: Block diagram clockwise rotation

4.2 Short description

The DC-Tacho-Generator TDP consists of a permanent magnet stator for excitation and a rotor from which DC voltage is drawn via carbon brushes. The rotating rotor generates a DC voltage at a given linear relationship in proportion to its speed.

4.3 Connections

The terminal box is fitted with cable glands. Suitable cables (Pg 11, cable Ø 7.5-9) are necessary to maintain the degree of protection.

Electrical connection:

- Clockwise rotation: A1 terminal positive
A2 terminal negative
- Winding test (repeat) max. 500 V
- Suitable connection cable to maintain degree of protection

Fit cover plate and terminal box lid,
machine is ready for operations!

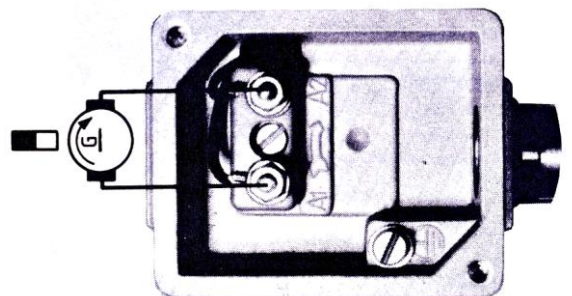

5 Transport, packaging and storage

5.1 Safety instructions for transport



CAUTION!

Improper transport can cause property damage!

Comply with the symbols and warnings on the packaging.

- Handle with care
- Protect from moisture
- Protect from heat over 40°C and direct sunlight

5.2 Incoming goods inspection

Check delivery immediately upon receipt for completeness and possible transport damage.

Inform the forwarder directly on receipt of the goods about existing transport damages (prepare pictures for evidence).

5.3 Packaging (disposal)

The packaging is not taken back and must be disposed of in accordance with the respective statutory regulations and local guidelines.

5.4 Storage of packages (devices)



Protect from moisture

Keep packed goods dry and protected against moisture.

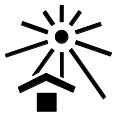

Protect from heat

Protect packaged goods from heat over 40°C and direct sunlight.

If stored for longer periods (> 6 months) we recommend sealing the devices in foil, possibly with a desiccant.

5.5 Uses

DC-Tacho-Generators from the series TDP 0.7 are used to convert rotary motion (rpm) to DC voltage in proportion to the rotating speed. These encoders are suitable for deployment with larger industrial drives such as those used in steel and rolling mills, in coal mining operations, in process technology, in railway systems, in power plants, in marine engineering and so on.

5.6 Place of installation

- Installation height \leq 1000 m above msl. Consult the manufacturer if the installation height is $>$ 1000 m (possible derating)
- Permissible ambient temperature - 40 °C to + 100 °C.
- Avoid too dry ambient conditions (ensure patina build-up on carbon brush/commutator).
- Observe details on nameplate (ratings, protection class and so forth) when operating the DC tacho-generator.
- Do not attach or lean temperature sensitive components onto or against the machine; do not position such components in the immediate vicinity of the machine.
- Ensure sufficient space is available for maintenance work (please refer to 8.2 Inspection and maintenance schedule)
- We recommend installing a canopy for model designs and shaft ends facing downwards; fit a cover on the plant side if the shaft end faces upwards.
- The owner must ensure that no system resonance or vibration arise from interaction between the machine and plant that could impair the functioning of the machine or result in damage to the machine or the entire plant or accelerate the ageing process (of the bearings, for example).
- It is the owner's responsibility to undertake suitable measures at the place of installation that ensure the devices and plant in their totality fulfil the relevant standards applicable to electromagnetic compatibility.

5.7 Installation work

5.7.1 Installation and commissioning

! Caution!



- It is the owner's responsibility to ensure that all moving parts are properly safeguarded and ensure that the machine is safe to operate!
- Observe the max. permissible voltage when repeating the winding test (contact the manufacturer).
- It is essential to prevent the ingress of oil or grease into the commutator area! Oil mist as well as touching the carbon brushes with oily fingers will cause the carbon brushes to wear significantly; this in turn will lead to the commutator becoming greasy and short-circuits between the segments.

Please note:

- It is the owner's responsibility to ensure that all moving parts are properly safeguarded and ensure that the machine is safe to operate!
 - Observe the max. permissible voltage when repeating the winding test (contact the manufacturer).
 - It is essential to prevent the ingress of oil or grease into the commutator area! Oil mist as well as touching the carbon brushes with oily fingers will cause the carbon brushes to wear significantly; this in turn will lead to the commutator becoming greasy and short-circuits between the segments.
1. Use a zero-play coupling. The armature must rotate easily; the carbon brushes must sit properly in the brush holders.
 2. Ensure precisely centred assembly. Angular misalignment and parallel displacement lead to additional harmonics. Align added device referring to a harmonics oscillogram (<5‰). Fit and align overhanging devices with due care and attention. Observe maximum permissible radial eccentricity 0.05 mm. Do not allow radial or axial forces to act on the tacho-generator shaft.
 3. Secure machine using flange or foot.

Mount the machine securely without distortion and not subject to vibration. Securely fasten the feet or flange using standard screws and washers in all of the through holes. It is important to ensure the correct property class, size and length of engagement on the fastening side (in accordance with VDI 2230 Blatt 1) so that the entire system remains securely and reliably mounted under all operating statuses. The thread engagement, its stability and strength on the fastening side must be guaranteed at all times.

The screws must be tightened to the appropriate torque for the property class and thread; screws must not become loose when the machine is in operation or at a standstill. Use a torque wrench. Regularly check the fastening screws are seated correctly in accordance with the inspection and maintenance schedule. Use only flexible couplings; align and adjust the tacho-generator exercising due care and attention.

Fit coupling components or other fastenings with due care and attention. Support the opposite end of the shaft (blows will damage the bearings).

If the second shaft is not used secure the key permanently to ensure it cannot be thrown out of the keyway.

4. Connections in the terminal enclosure.

Check the load against the technical data detailed on the nameplate. **Please note:** Take account of surge protectors for downstream devices, if these are connected to the output voltage of the tacho-generator. The output voltage of the tacho-generator increases at a given (linear) relationship in proportion to the speed.

- Connect according to circuit diagram (see wiring diagram).
- To guarantee a safe electrical connection the cross-section of the conductors must be sized in accordance with the rated current as detailed on the nameplate.
- Ensure any unused cable glands and the terminal box are sealed dust and water-tight
- Create a safe earth connection!

Before closing the terminal box you must ensure that

- The connections have been terminated according to the wiring diagram.
 - All connections in the terminal box have been securely tightened.
 - All minimum clearance values have been maintained (greater than 8 mm up to 500 V, greater than 10 mm up to 750 V)
 - The inside of the terminal box is clean.
 - Unused cable glands are sealed and the screw plugs including the seals are tightened securely.
 - The gasket seal is clean and properly glued in the lid of the terminal box; ensure all sealing surfaces are in a proper condition to guarantee the degree of protection.
 - The rating data match the data detailed on the nameplate.
5. Remove any transport locks before commissioning.

5.8 Dismantling

Observe and adhere to safety information (2)!

- Shut down and ensure the machine cannot be restarted.
- Turn off and isolate the power supply; turn off and isolate the power supply to any additional or auxiliary circuits.
- Ensure adjacent live components are insulated and safeguarded.
- Examine components for damage and broken edges (for example risk of cuts from broken off foot).
- Exercise due care and attention when removing coupling parts and fastenings; support the opposite end of the shaft (blows will damage the bearings). Coat the shaft with a thin layer of oil and seal with screw cap. Ensure the terminal box and cable glands are sealed dust and water-tight; ensure the degree of protection (see nameplate) is achieved and guaranteed for transport.
- Observe and adhere to transport information (5)!
- Ensure that the packaging (carton + palette) used to transport the machine is correctly sized and that the machine is secured by the packaging in such a manner that forces resulting from the weight of the machine during transport cannot cause any damage to the machine, to neighbouring parts or injury to personnel! Use transport locks to reduce the load acting on the bearings.

Dismantling (disassembly / removing the armature) the fully assembled tacho-generator TDP 0.7 must always be undertaken by the manufacturer only.

6 Disorders

In disorders that can not be eliminated by the following instructions, the manufacturer is looking for, see service address on page 2.

6.1 Diagnosis Chart

Disturbance	Possible cause	Troubleshooting
Voltage to low	Wrong speed	Speed measurement control
	Winding short	Voltage check Consulting producer
	Maximum permissible current is exceeded	Reduce current.
	Irrreversibler damage the magnets (aging)	Magnets magnetize new (consult manufacturer).
Voltage values at different rotation unequal	Neutral zone adjusted.	Consulting producer
	Bias excitation field by armature reaction.	Consulting producer
	Reversion, tilt the brush in the holder.	Consulting producer
Harmonics	Burn marks on the commutator, for example by short circuits.	Cause for short circuits and repair
	Coupling or assembly errors (misalignment and parallel misalignment).	Correct the mounting mistake
	System-related vibrations and resonance	Possible causes, contact the manufacturer.
Rotor rotating hard	Armature short circuit, defective storage	Decouple machine to look again, a hard place? Contact the manufacturer.
Grinding noise	Carbon brush holder from fallen.	Brush back into holder, avoid strong vibrations.
	Rotating parts sand.	Grinding cause notice. If possible! Remove foreign matter otherwise contact manufacturers.

Bearing makes noise or is jammed Note: Exchange of the bearings only by the manufacturer.	Mounting error / clutch problem	Mounting precision check
	Corroded bearings	Replace bearing by manufacturer
	Insufficient lubrication.	contact the manufacturer.
	Too little/much bearing play.	Replace bearings Contact the manufacturer
	Grind marks in the bearing track, scoring.	Replace bearings; contact the manufacturer.
	Bearing jammed or distorted	Check bearing bore contact the manufacturer.
	Seals rub	Replace seal. Please contact the manufacturer
	Insufficient lubrication	Please contact the manufacturer
	Bearing corroded	Please contact the manufacturer.
	Too little bearing play	Please contact the manufacturer
	Coupling pushes or pulls	Re-align machine
	Belt tensioned too tightly	Adjust belt pulley in line with specifications.
	Bearings jammed or distorted	Contact the manufacturer
Heavy vibration	Rotor imbalance, rotor not round, shaft distorted	Please contact the manufacturer
	Incorrect alignment	Align set of machines; check coupling.
	Imbalance with the coupled prime mover	Rebalance the coupled prime mover
	Shocks from coupled prime mover	Check prime mover
	Resonance in the foundations	Strengthen foundations following consultation with the manufacturer
	Changes in the foundation	Following consultation with the manufacturer determine the cause, eliminate error and realign the machine.
Carbon brushes wearing excessively	Brush contact resistance too high – badly formed patina (brush contact face -	Change condition of circulating air (remedy lack of moisture;

D.C. tachometer generator TDP 0,7

	commutator contact face) as a result of the air being too dry.	avoid dust in ambient air).
	Brush pressure too high	Contact the manufacturer.
	Grease on brush contact face	Clean contact face (contact the manufacturer)
	Heavy vibration	* See above.
Surface temperature too high (>100 °C)	Operated under short-circuit conditions	Check device; please contact the manufacturer.
Other faults		Please contact the manufacturer.

6.2 Inspection and maintenance schedule

PLEASE NOTE!
No other actions are required to be carried out on the device in addition to the following cyclical inspections described in this inspection schedule. Any attempt to tamper with the device will result in the warranty being declared null and void!

Caution! Replace the sealing ring on special versions (tacho-generators with speed increasing gear) after 5000 to 8000 hours of operation. Blow out metal filter of tacho-generators designed with ventilation vents (IP 55 spec.).

Contact the manufacturer when operating any other special version and combinations of devices (e.g. TDP 0.7 + FSE 102).

Interval	Inspections	To be carried out by
Regularly	Check fastening screws are seated correctly	Skilled personnel
After approx. 2000 operating hours	Check carbon brushes; blow carbon brush dust out of the machine using dry, oil-free compressed air; check ease of movement. When changing carbon brushes (service life approx. 10 000 – 20 000 operating hours depending on environmental conditions and speed) ensure the new brushes are of the same quality and type. Please note: Double tacho-generators have 2 commutators and 2 brush rockers).	Skilled personnel
After approx. 2000 operating	Clean soiled commutators using a clean,	Skilled personnel

hours	oil-free cloth. Do not remove smooth patina build-up from contact face. Remove grooves and polish surface using fine Emery cloth or skim on lathe (possibly recut and dubburr slots).	
Every 48 months	Check ball bearings for noise, running smoothly. Service life approx. 20 000 hours (lubricated for life); however, service life depends on speed, environmental conditions and load. Caution! Do not remove the armature before short-circuiting the magnetic circuit using an appropriate short-circuiting ring (otherwise voltage drop of approx. 25%). Observe dismantling instructions!	Bearings must be replaced by the manufacturer or a certified workshop only.
Regularly (depending on degree of soiling)	Cleaning: Blow-clean the machine using dry, oil-free compressed air. Do not use cleaning agents that damage the coating. Do not use inflammable cleaning agents.	Skilled personnel
Regularly	Check coating. If the protective coating is sufficiently damaged, repaint to prevent risk of corrosion (recommended).	Skilled personnel
If the machine has not been in use for a long time (more than 6 months).	Check the insulation resistance of the windings (greater approx. 1-5 mega-ohm). To measure the insulation resistance disconnect all outgoing lines from the generator. Contact the manufacturer if the resistance reading is less than 1 mega-ohm.	Skilled personnel

7 Disposal

7.1 Disposal procedure

The manufacturer is not obliged to take back the device.

The device is classed as electronic equipment and subject to the WEEE Directive; observe local, country-specific laws when disposing of the device.

For information on environmentally sound disposal please contact your local authority or a specialist disposal company.

8 Spare parts

Spare parts are available on demand via the service address on page 2.



NOTE!

When ordering spare parts, always state the serial number of the device!

9 Annex

9.1 Connection diagram

Electrical connection:

- Clockwise rotation: A1 terminal positive
A2 terminal negative
- Winding test (repeat) max. 500 V
- Suitable connection cable to maintain degree of protection

Fit cover plate and terminal box lid,
machine is ready for operations!

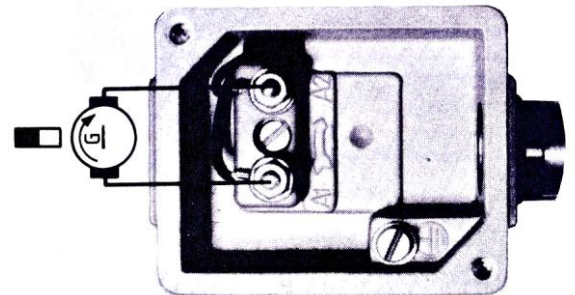

TDP 0,7 ...

Clamping strip (Terminal box):

10 Dimension drawings

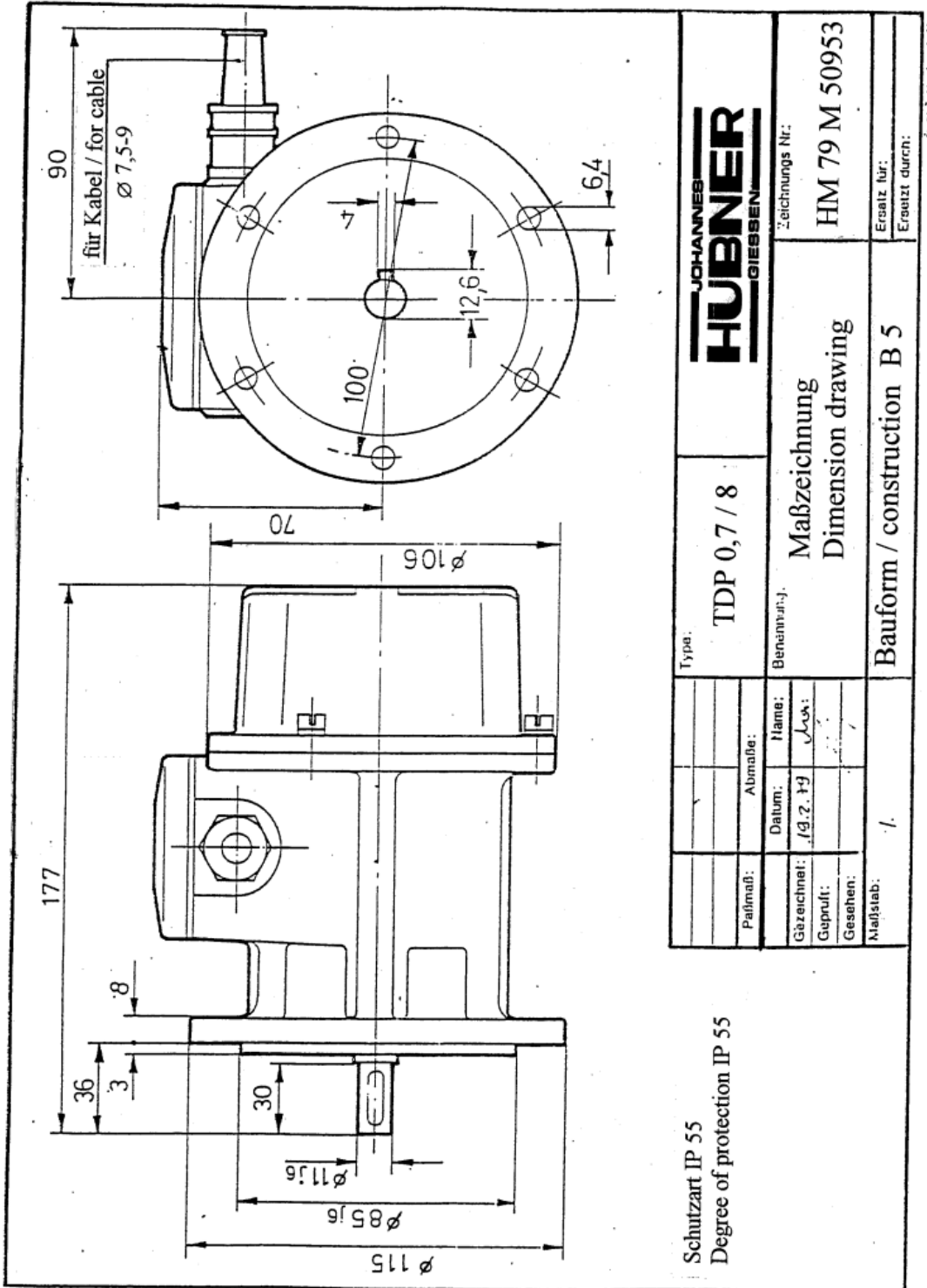

Schutzart IP 55
Degree of protection IP 55

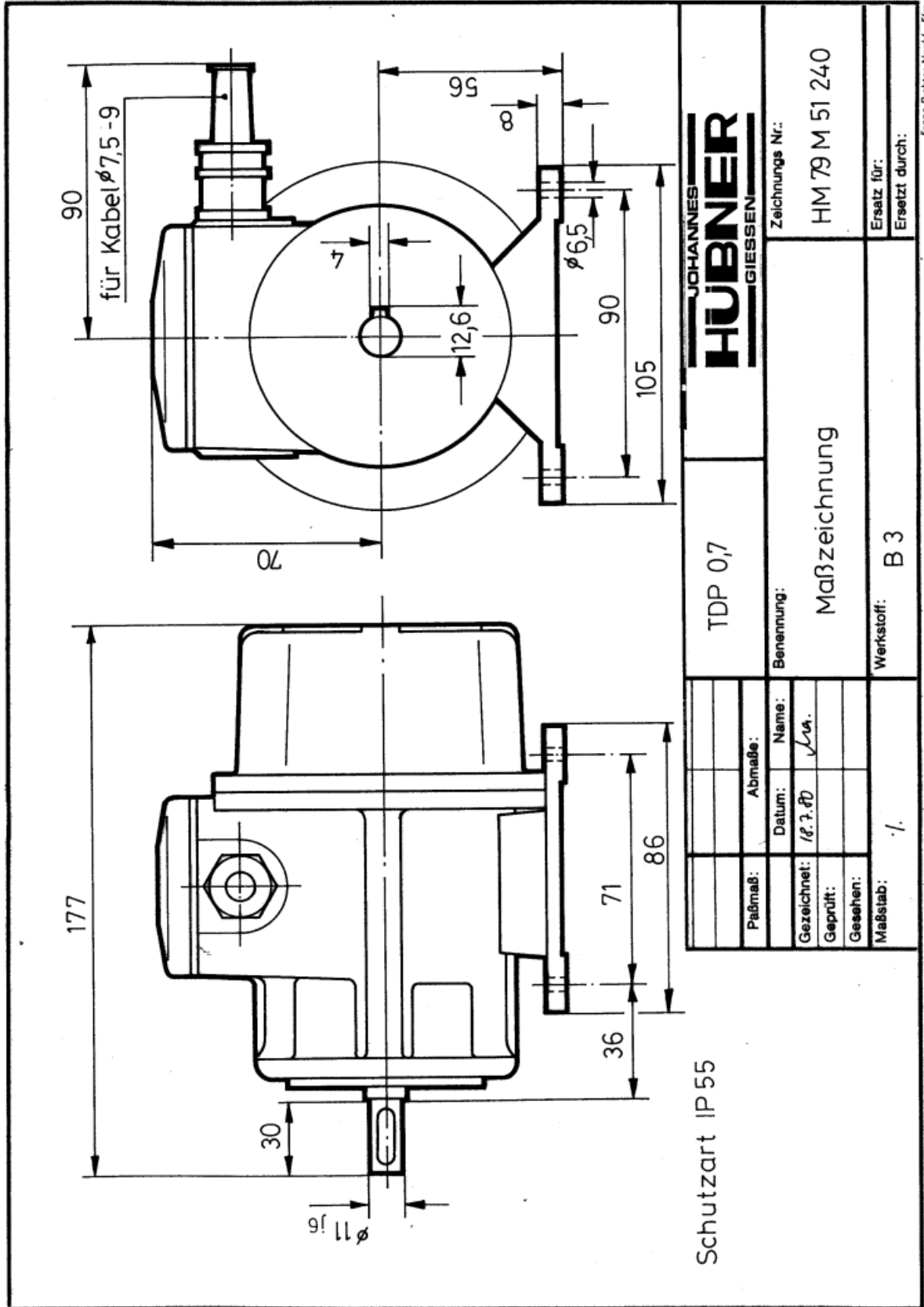

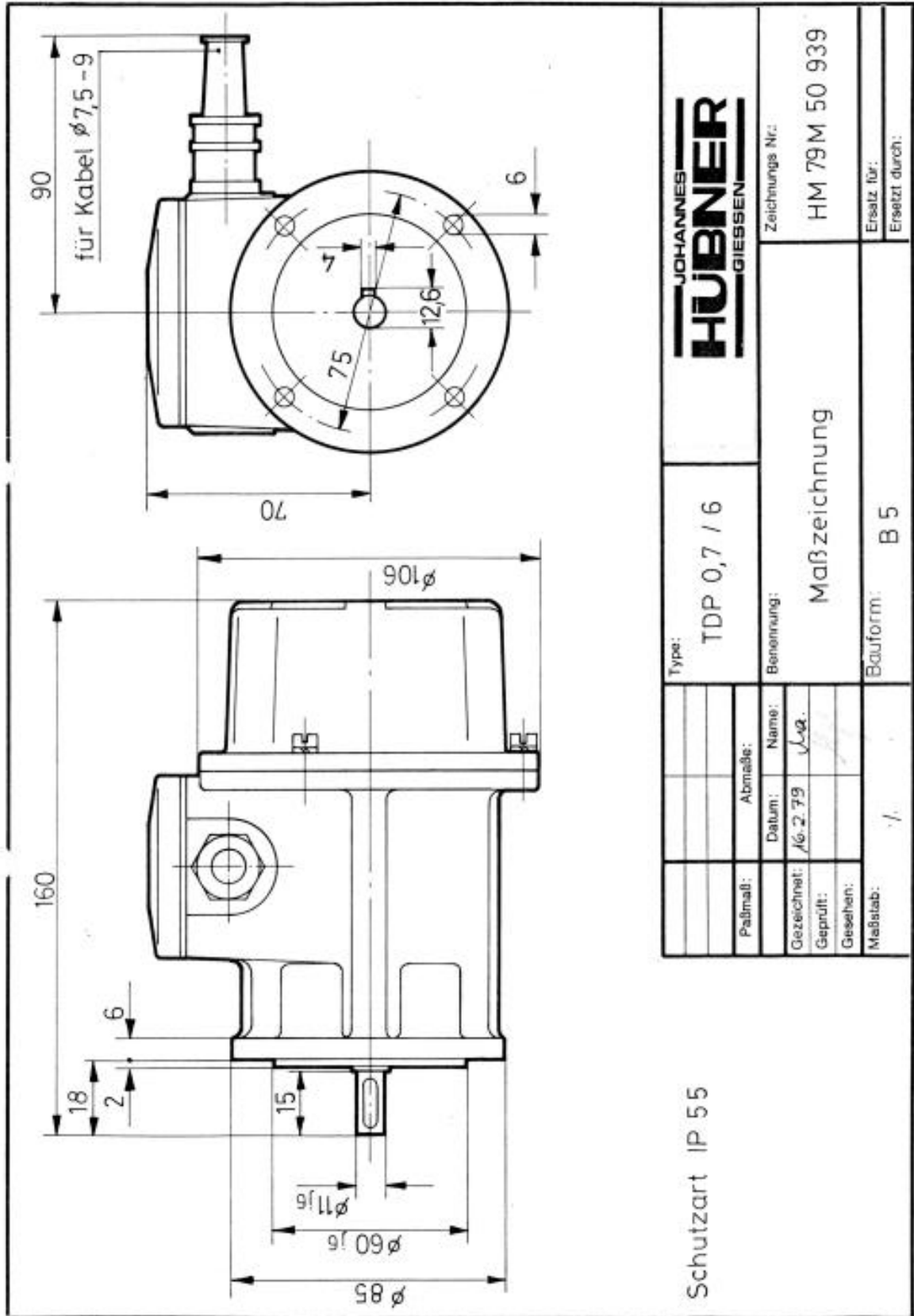

Franz Rieder Nachf. / fm

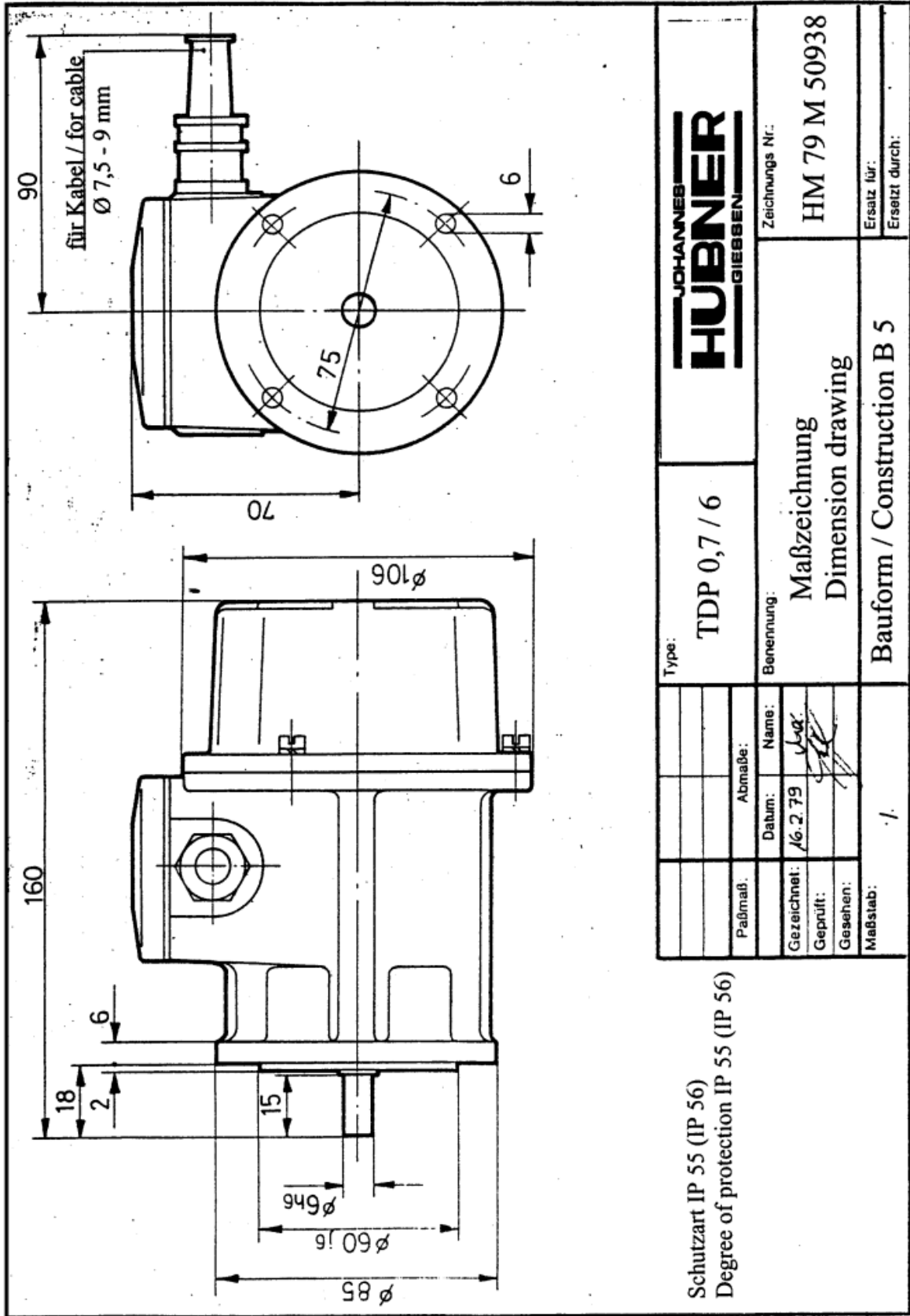

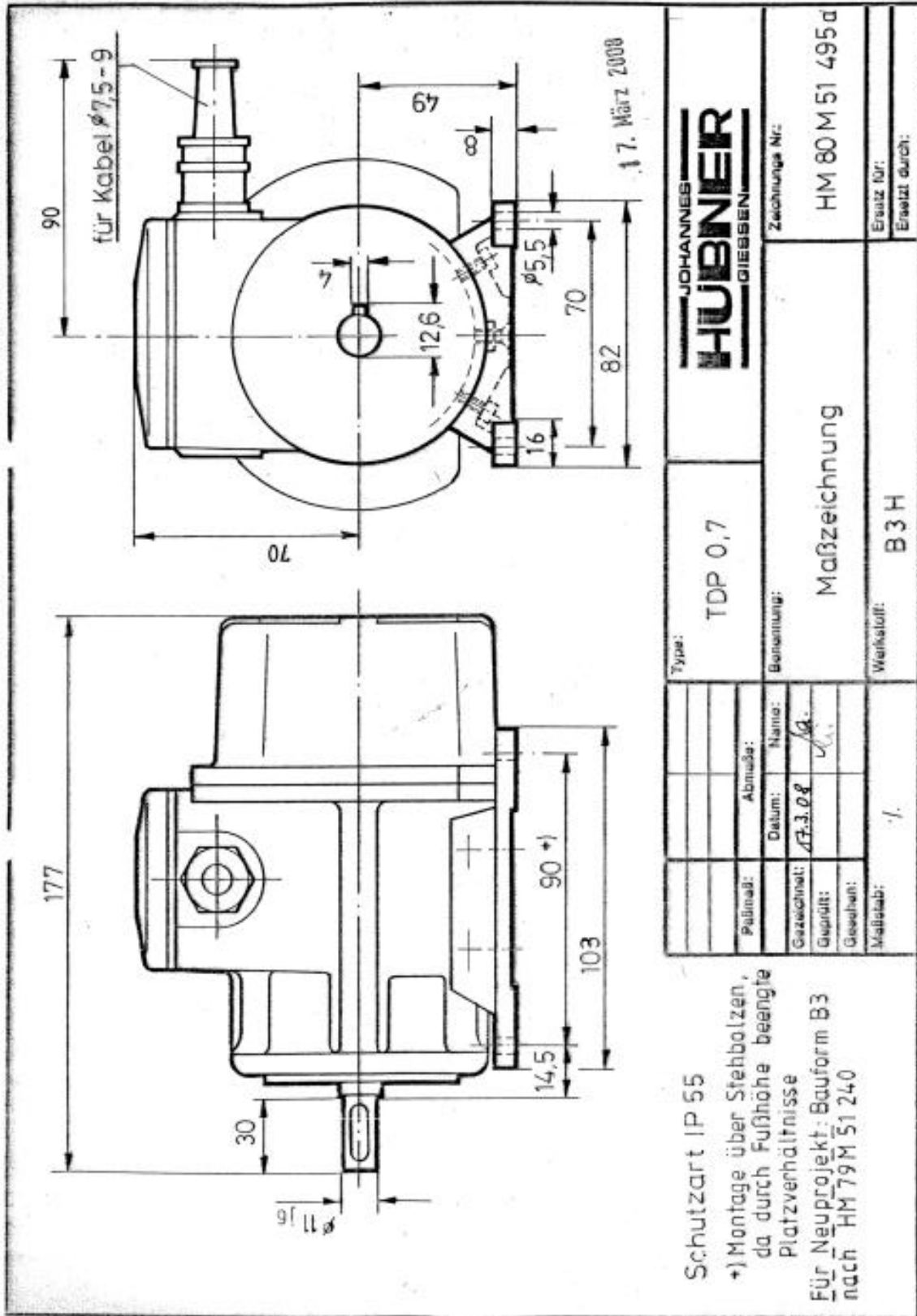

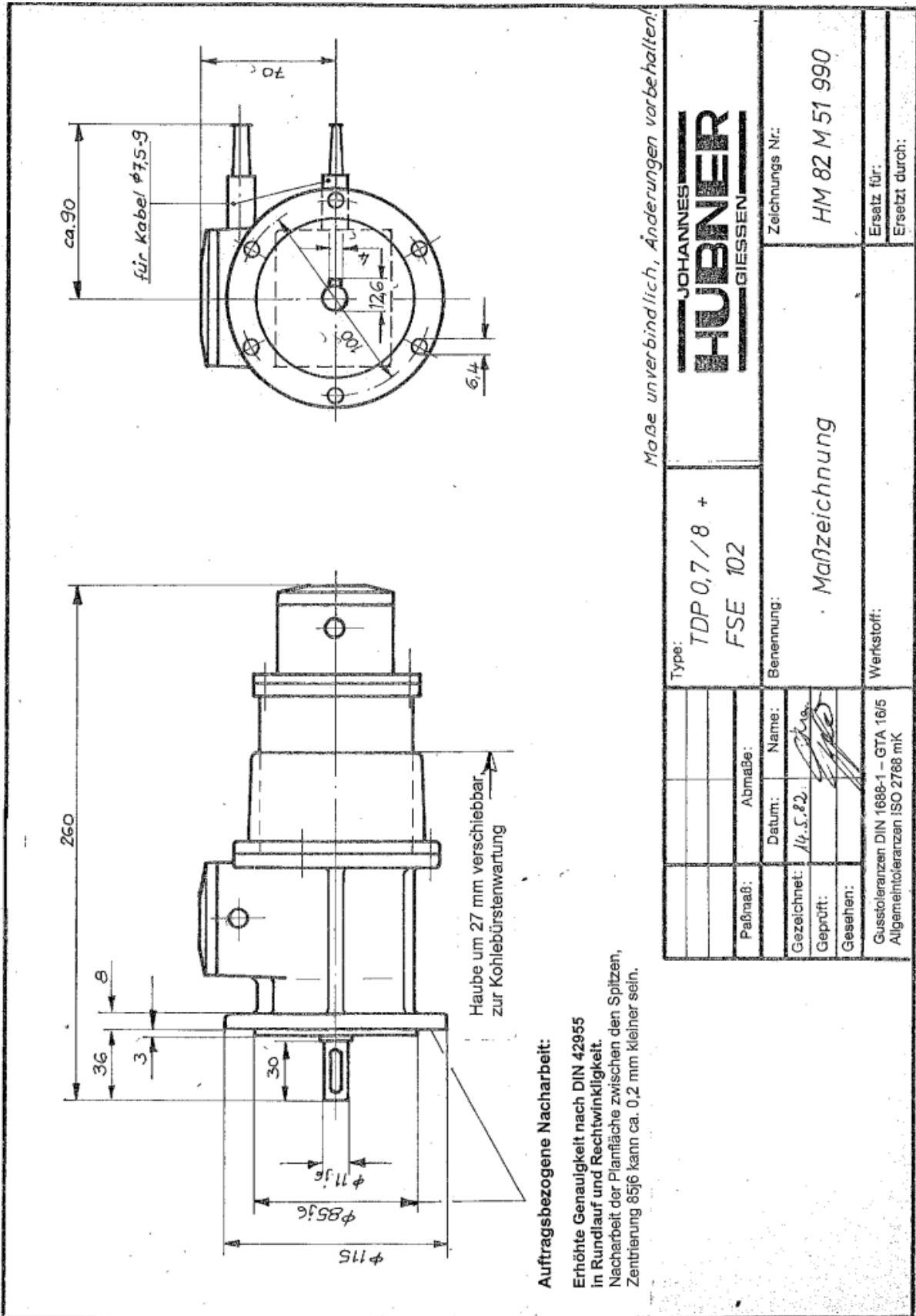

Weight TDP 0,7: approx. 2,5 kg / mass moment of inertia: 0,44 kgcm².

10.1 Screw tightening torques

Screws used to mount the machine (screw material, the material pairings to be fastened and the length of thread engagement) are to be calculated to VDI 2230 (Page 1). The materials used and the construction to which the generator is to be fastened must guarantee a permanently secure and reliable joint. The owner is obliged to inspect and ensure compliance with all specifications.

11 EC- Declaration of Incorporation

	
EC-Declaration of Incorporation of Partly Completed Machinery	
In accordance with the EC machine directive 2006/42/EG of 17. May 2006, appendix II B	
We hereby certify that the following described machine in it's conception, construction and form put by us into circulation is in accordance with all the relevant essential health and safety requirements of the EC machinery directive 2006/42/EEC as amended and the national laws and regulations adopting this directive. This declaration is no longer valid if the machine is modified without our consent. Commissioning of machine is permitted only provided that the components installed in the machine do comply with the relevant directive standards 2006/42/EG).	
Manufacturer: Johannes Hübner Fabrik elektrischer Maschinen GmbH Siemensstrasse 7 D-35394 Giessen/Germany	
Description of the machine: function: D.C. Tachometer Generator type/model: TDP 0,7	
The agreement includes the conformity declaration guidelines/regulations of the following products:	
EMV – directive (2004/108/EC) of December 15, 2004 EEC low – voltage directive 2006/95/EC of December 12, 2006 (valid for these units with nominal voltage of 50 V – 1000 V AC/ 75 V – 1500 V DC)	
We declare that special technical information for this incomplete machine is according to appendix VII, part B and we obligate us, to submit this information through the Head of QM to the market supervisory authorities on demands.	
Authorized person for the technical documentation: Gerhard Esch QMD (Head of QM) at the above address	
Signature:  Martin Eilers	Date: 23.11.2010

A		
Annex	24	
C		
Connection diagram	24	
Connections	14	
Construction and Function	14	
Copyright	6	
Customer service	6	
D		
Diagnosis Chart	20	
Dimension drawings	25	
Dimensions, Power consumption, Environment, Speed	10	
Directory	3	
Disclaimer	6	
Dismantling	19	
Disorders	20	
Disposal	24	
Disposal procedure	24	
E		
EC- Declaration of Incorporation	32	
Electrical current	8	
Elektrical and mechanical data	11	
Ensure the power supply cannot be reconnected .	8	
Explanation of symbols	5	
G		
General	5	
General technical data	12	
Guarantee terms	6	
I		
Improper use	7	
		Incoming goods inspection
		Information about the operating manual
		Inspection and maintenance schedule
		Installation work
		Intended use
		P
		Packaging (disposal)
		Personal protective equipment
		Personell
		Place of installation
		R
		Responsibility of the owner
		Rotating shafts and hot surfaces
		S
		Safety
		Safety instruction for transport
		Scope of delivery
		Screw tightening torques
		Short description
		Spare parts
		Special dangers
		Storage of packages (devices)
		T
		Technical Data
		Transport, packaging and storage
		Type key
		Type plate
		U
		Uses