

Zentrierung / centering DIN 332 Bl.2 - DS M...

zur Justage, 3 x Kugeldruckschraube M12
for adjustment, 3 x ball thrust screws M12

Montageanleitung Nr. 55 190
und Nr. 54 570-2 beachten!
Please note mounting instruction
no. 55 190 and no. 54 570 - 2

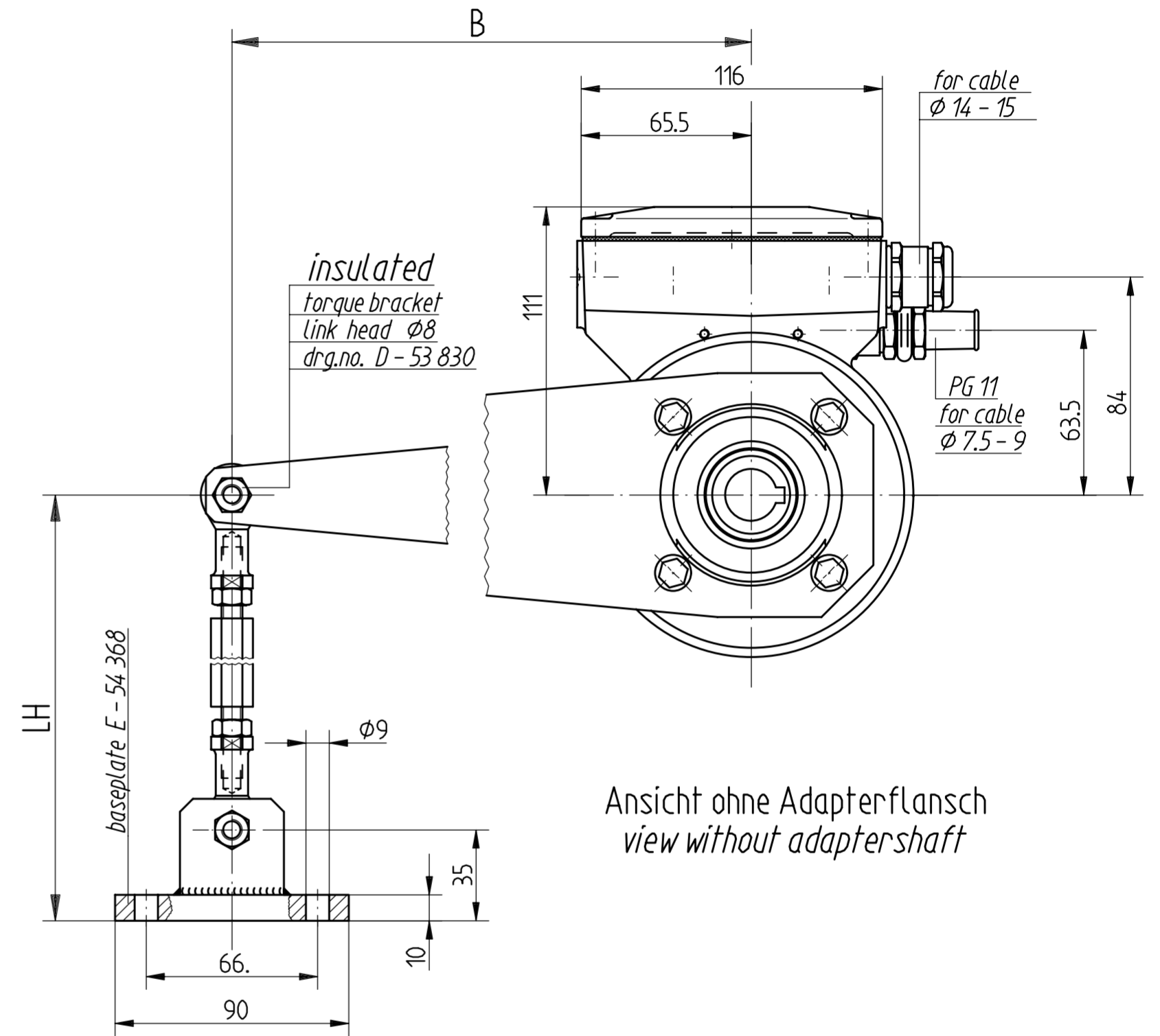

Ansicht ohne Adapterflansch
view without adaptershaft

Nach Zusatzdaten-
blatt
see additional
data sheet
B=...
LH=...

Anderungen vorbehalten
modifications reserved

M16	23	60	31	6	~1	25	46	D - 55 531	Bauform : Hohlwelle construction : hollow shaft	1999 Bearb. Gepr. Norm	Datum 14.10.	Name M. Weiner	Maßstab	1:2	ID-Nr.	13 497
M20	28.4	69	38	8	~1.3	39.5	24	D - 54 556					Maßzeichnung / Dimension Drawing			
M24	34.2	69	45	10	~1.6	19	55	D - 54 766					Benennung	FGH 4K + FSE 102		
3/4" UNC	29	79	37	9	~1	32	30	D - 56 279					Zeichnungs-Nr.	HM 99 M 54 958	Blatt	
1" UNF	32.7	78	37	7	~0.8	23	55	D - 54 835					Ers.f.:	Ers.d.:	Bl.	
d	d ₄	D	l	l ₁	t ₅	h ₁	SW	Zchnng. Nr. / dwg. No.	a. Ind. Tabelle hinzu Zust. Änderung	09.06.05 Datum	Eckh. Name	Urspr.				