

Antriebswelle / drive shaft

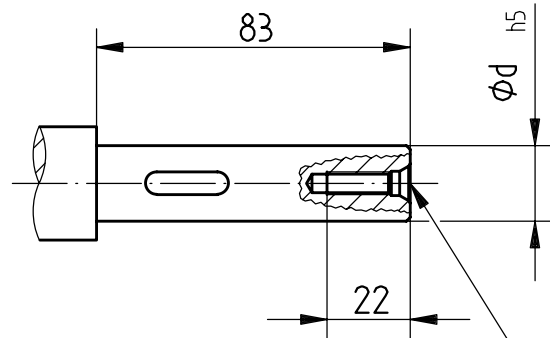

Zentriergewinde / centering thread
DIN332, Blatt / sheet 2 - DS M6

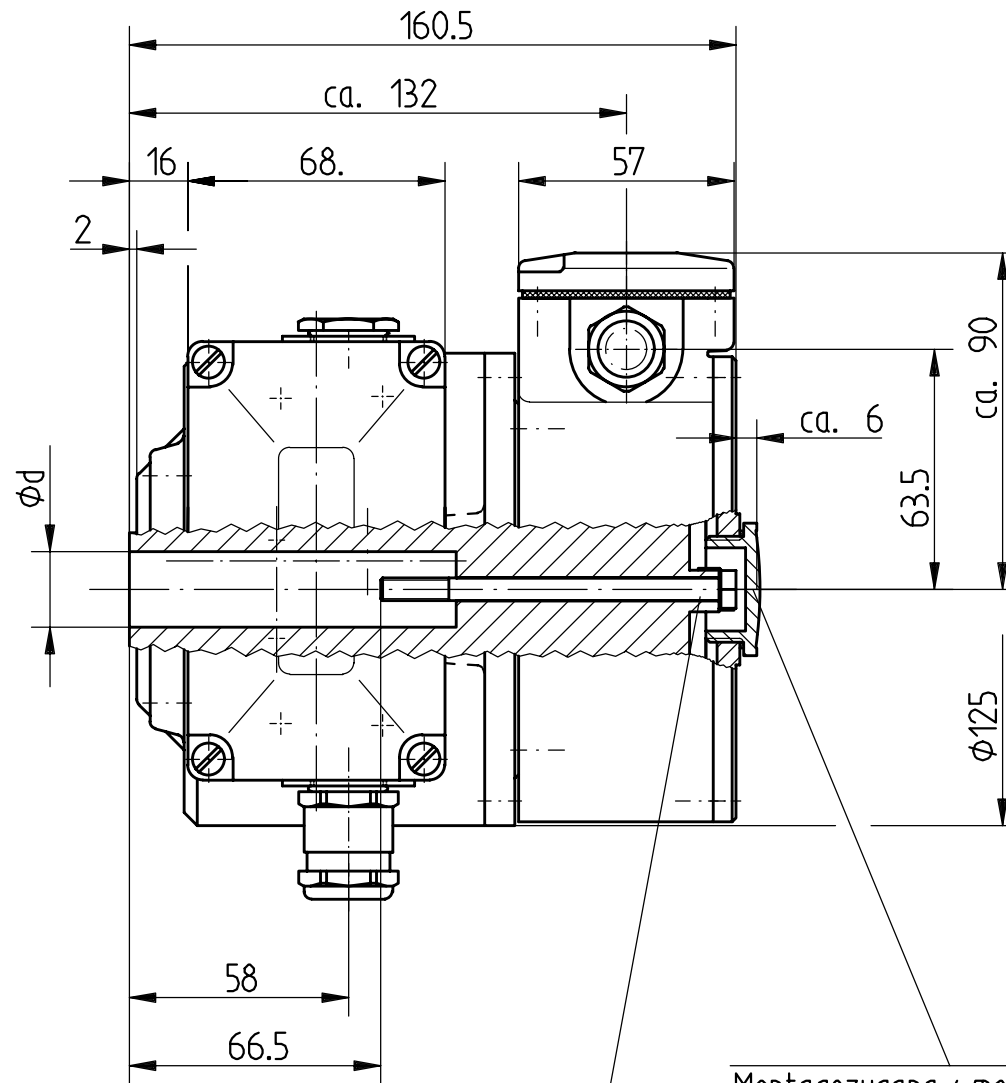

Montagezugang / mounting access
Verschlußschraube PG 21, SW 32
screw plug PG 21, size 32

Skt.-Schraube / hex head screw
DIN 931 - M6x90
Sicherungsblech / locking plate
DIN 463 - 6,4

Sicherungsblech umbiegen!
bend over locking plate!

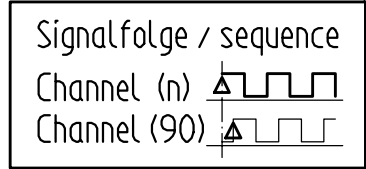
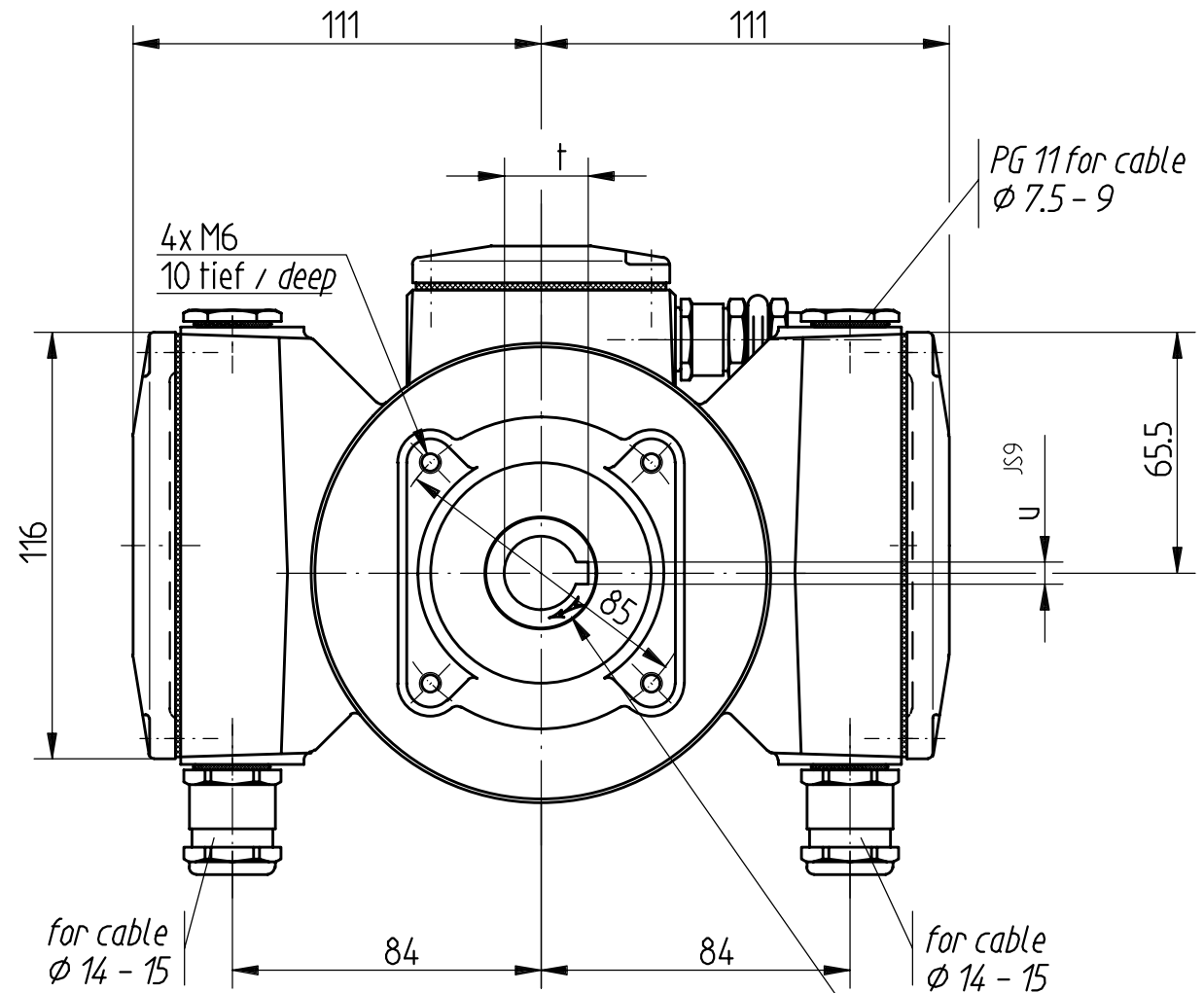

d	t	u	Paßfedernut nach DIN/ keyway to DIN
20	22.8	6	6885 BL. / Sh. 1
19	21.8	6	
22	23.2	6	ohne DIN / without DIN

Drehmomentenstuetze nach Zchnng. Nr. /
Torque bracket acc. to dwg. No.
D - 52 162 bzw. / or D - 52 163

Anderungen vorbehalten
modifications reserved

Bauform : Hohlwelle construction : hollow shaft		Maßstab 1:2	ID-Nr. 12 069
		Maßzeichnung / Dimension Drawing	
		Benennung FGH4 KK + FSE 102	
		Zeichnungs-Nr. HM 96 M 54 228 KK	
		Blatt BL.	
Zust	Anderung	Datum	Name
			Urspr.
		Ers.f.:	Ers.d.:

