

### Magnetic encoder Type MAG 160...1200

Magnetic encoder without own integrated bearings



#### Field of application e.g.:

- Drive shafts for ships
- Motors for open-pit shovels
- Shaft connections between tandem test stand motors
- Gas and water turbines
- Motors/generators with large shaft diameters
- Particularly suitable for retrofitting utilizing split constructions (optional)

#### Advantages

##### Magnetic scanning principle

- Resistant to soiling
- Considerable air gap and axial shifting possible (e.g. necessary for moveabel bearing end of motor)

##### Without integrated bearings

- Large hollow shaft diameter possible
- Wear-free
- No heating
- Low noise
- More cost-effective than hollow shaft encoders with integrated bearings



Option:

Explosion proof design

ATEX ZONE 2  
other zones on request

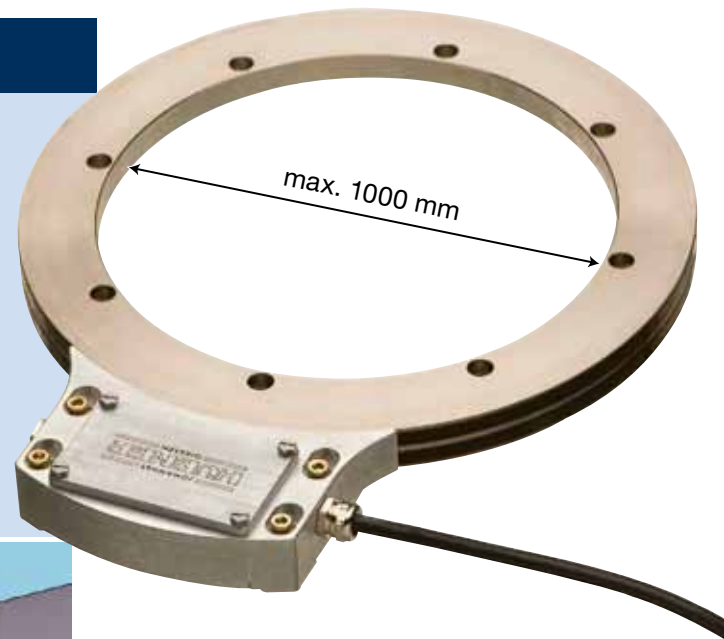

#### Magnetic encoder

- 1 Basic channel
- 2 Reference pulse
- 3 Protects magnetic track: wrapping

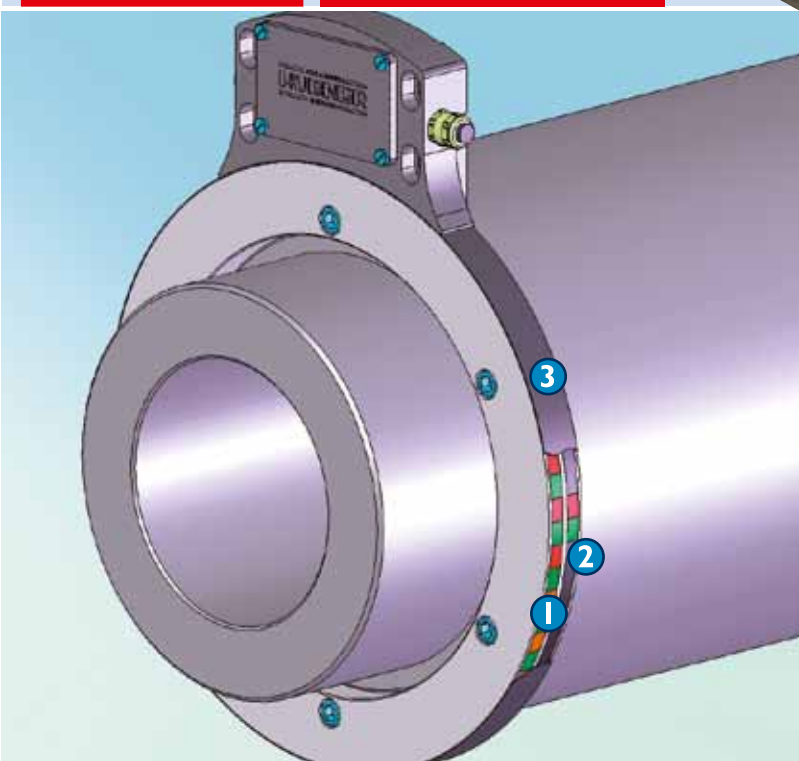

## Magnetic incremental encoder Type MAG 160...1200

### Type overview

Type	Max. hollow shaft	Pulse rates
MAG 160	100 mm	100, 200, 300 .... 1000
MAG 200	140 mm	128, 256 ... 1024 ...
MAG 240	175 mm	150, 300, 450 ... 1500
MAG 320	250 mm	200, 400, 600 ... 2000
MAG 400 - 250	340 mm	250, 500, 750 ... 2500
MAG 400 - 256	340 mm	256, 512 ... 1024 ... 2048 ...
MAG 480	415 mm	300, 600, 900 ... 3000
...	...	...
MAG 1200	max. 1000 mm	

further pulse rates on request

### Electrical data

Pulse rates:	see table (square pulses)
Supply voltage:	12...30 V DC
No-load current consumption:	approx. 50 mA
Max. frequency:	100 kHz
Temperature range:	-40°C ... +85°C
Output signals:	0°-signal (A) and inverted signal ( $\bar{A}$ ) 90°-signal (B) and inverted signal ( $\bar{B}$ ) Reference pulse (N) and inverted signal ( $\bar{N}$ ) Error output (ERR) and inverted signal ( $\bar{ERR}$ )
Signal amplitudes:	HTL (corresponds approx. power supply voltage)
Output current:	60 mA
Pulse duty factor:	1:1 ± 5% (up to interpolation factor 16)
Phase displacement A, B:	90° ± 10° (up to interpolation factor 16)

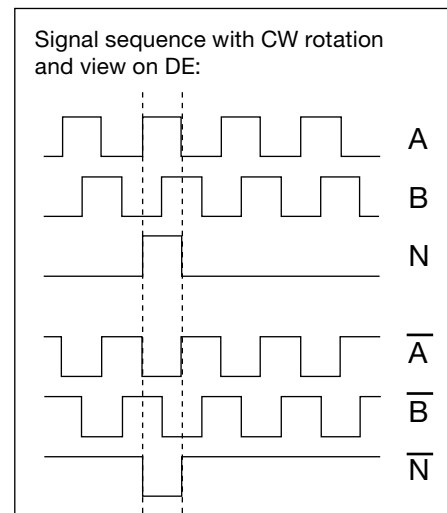

### Elektrical connections

- Large terminal box, 10-pole spring cage connector board
- EMC cable gland for cable Ø 9...13 mm
- Connection possible on both ends of the scanning head
- Connection diagram PN 109-400

Option:  
12-pole Burndy plug  
Fibre-optics signal transmission

### Mechanical data

Mechanical construction: centering matched to the customer shaft  
Dimension drawing: on request  
Degree of protection: IP66 ... IP68 (EN 60529) dependent on the kind of connection  
Axial tolerance: ± 3 mm (Shift - rotor pole/scanning head)  
Radiale Toleranz: 0,2...2,0 mm (Air gap - rotor pole/scanning head)